

SMA3107

ELECTRICAL CHARACTERISTICS ($T_A = 25^\circ\text{C}$, $V_{CC} = 3\text{ V}$, $Z_S = Z_L = 50\ \Omega$)

Symbol	Parameter	Conditions	Ratings			Unit
			Min	Typ	Max	
I_{CC}	Circuit Current		4.3	6.0	7.7	mA
G_p	Power Gain	$f = 1\text{ GHz}$	21.0	23.5	26.0	dB
		$f = 2.2\text{ GHz}$	22.0	24.5	27.0	
I_{SL}	Isolation	$f = 1\text{ GHz}$	33.0	38.0	-	dB
		$f = 2.2\text{ GHz}$	40.0	45.0	-	
R_{Lin}	Input Return Loss	$f = 1\text{ GHz}$	18.0	23.0	-	dB
		$f = 2.2\text{ GHz}$	10.0	13.0	-	
R_{Lout}	Output Return Loss	$f = 1\text{ GHz}$	27.0	32.0	-	dB
		$f = 2.2\text{ GHz}$	10.0	13.0	-	
NF	Noise Figure	$f = 1\text{ GHz}$	-	3.1	4.3	dB
		$f = 2.2\text{ GHz}$	-	3.6	4.3	
$P_{O(1dB)}$	Gain 1 dB Compression Output Power	$f = 1\text{ GHz}$	-10	-8	-	dBm
		$f = 2.2\text{ GHz}$	-11.5	-9.5	-	
f_u	Upper Limit Operating Frequency	3 dB down below fl at gain at $f = 1\text{ GHz}$	-	2.8	-	GHz

Product parametric performance is indicated in the Electrical Characteristics for the listed test conditions, unless otherwise noted. Product performance may not be indicated by the Electrical Characteristics if operated under different conditions.

NOTES: Pay attention to handling since it is liable to be affected by static electricity due to the high frequency process adopted.

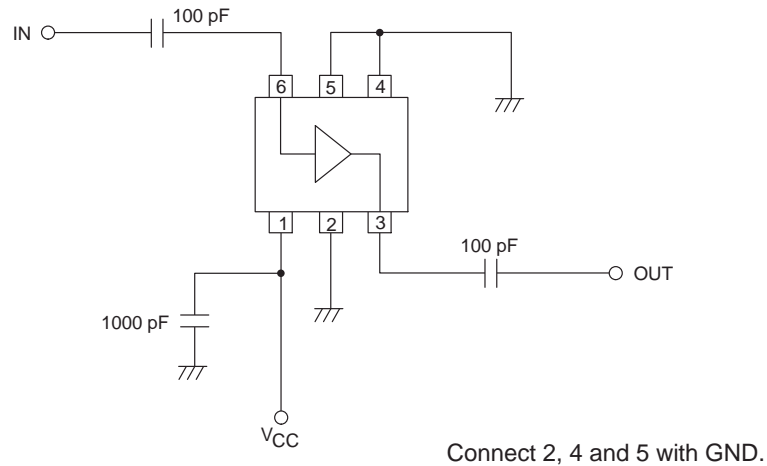
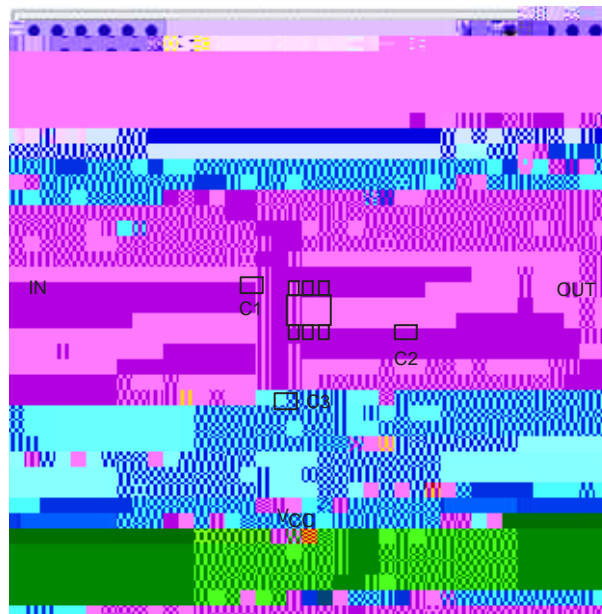

Figure 1. Test Circuit

SMA3107



Symbol	Value
C1, C2	100 pF
C3	1000 pF

Figure 2. Evaluation Board

SMA3107

TYPICAL PERFORMANCE CHARACTERISTICS

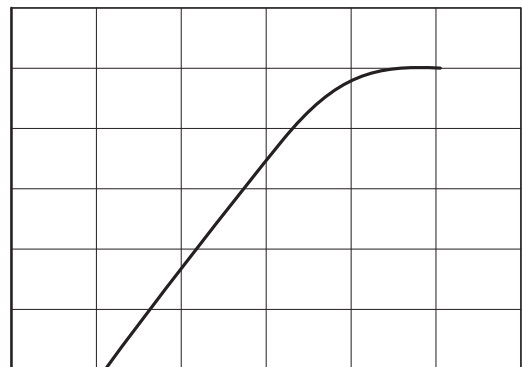
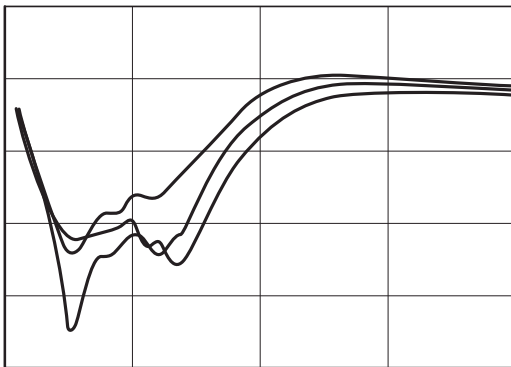
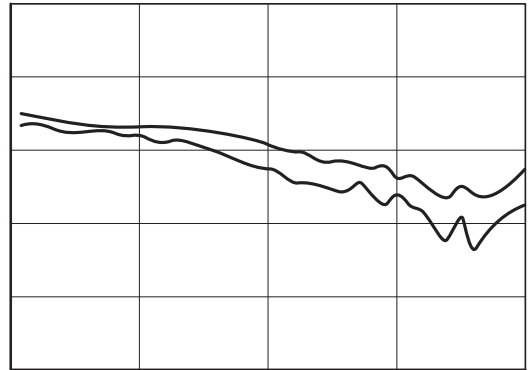

TYPICAL PERFORMANCE CHARACTERISTICS (continued)

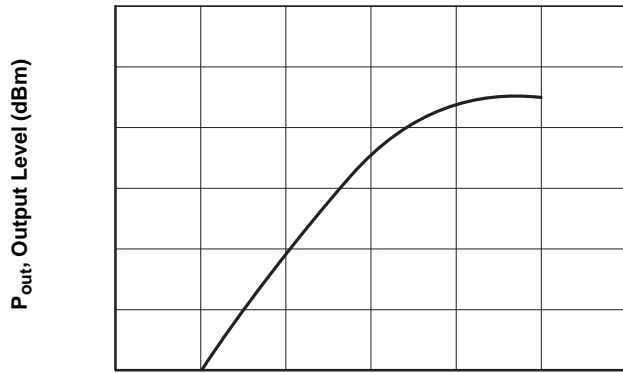

P_{in} , Input Level (dBm)

Figure 9. $P_{out} - P_{in}$

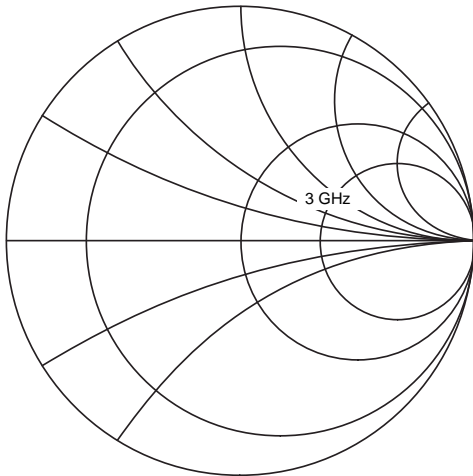
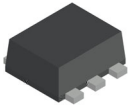

Figure 10. S Parameter, S11

Figure 11. S Parameter, S22



SC-88FL / MCPH6
CASE 419AS
ISSUE A

DATE 28 SEP 2022

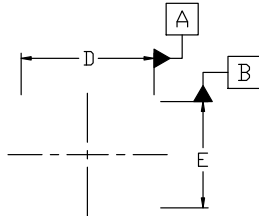

⌀ 0.1 (M) A

TOP VIEW

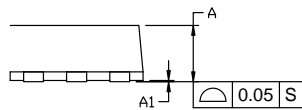

SIDE VIEW

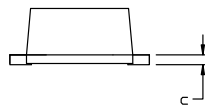

FRONT VIEW

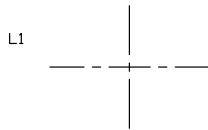

BOTTOM VIEW

NOTES:

1. NO INDUSTRY STANDARD APPLIES TO THIS PACKAGE.
2. ALL DIMENSIONS ARE IN MILLIMETERS.
3. DIMENSIONS ARE EXCLUSIVE OF BURRS, MOLD FLASH AND THE BAR PROTRUSIONS.

DIM	MILLIMETERS		
	MIN.	NOM.	MAX.
A	0.80	0.85	0.90
A1	0.00	---	0.02
b	0.25	0.30	0.40
c	0.12	0.15	0.25
D	1.94	2.00	2.06
E	1.54	1.60	1.66
He	2.05	2.10	2.15
L	0.19	0.25	0.31
L1	0.00	0.07	0.12

GENERIC MARKING DIAGRAM*

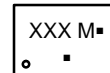

- XXX = Specific Device Code
- M = Date Code
- = Pb-Free Package

(Note: Microdot may be in either location)

*This information is generic. Please refer to device data sheet for actual part marking. Pb-Free indicator, "G" or microdot "▪", may or may not be present. Some products may not follow the Generic Marking.

onsemi, **onsemi**, and other names, marks, and brands are registered and/or common law trademarks of Semiconductor Components Industries, LLC dba "**onsemi**" or its affiliates and/or subsidiaries in the United States and/or other countries. **onsemi** owns the rights to a number of patents, trademarks, copyrights, trade secrets, and other intellectual property. A listing of **onsemi**'s product/patent coverage may be accessed at www.onsemi.com/site/pdf/Patent-Marking.pdf. **onsemi** reserves the right to make changes at any time to any products or information herein, without notice. The information herein is provided "as-is" and **onsemi** makes no warranty, representation or guarantee regarding the accuracy of the information, product features, availability, functionality, or suitability of its products for any particular purpose, nor does **onsemi** assume any liability arising out of the application or use of any product or circuit, and specifically disclaims any and all liability, including without limitation special, consequential or incidental damages. Buyer is responsible for its products and applications using **onsemi**
