

# NOA1211

## Ambient Light Sensor with Dark Current Compensation

### Description

The NOA1211 is a very low power ambient light sensor (ALS) with an analog current output and a power down mode to conserve power. Designed primarily for handheld device applications, the active power dissipation of this chip is less than 8  $\mu$ A at dark and its quiescent current consumption is less than 200 pA in power down mode. The device can operate over a very wide range of voltages from 2 V to 5.5 V. The NOA1211 employs proprietary CMOS image sensing technology from ON Semiconductor, including built-in dynamic dark current compensation to provide large signal to noise ratio (SNR) and wide dynamic range (DR) over the entire operating temperature range. The photopic optical filter provides a light response similar to that of the human eye. Together the photopic light response and dark current compensation insures accurate light level detection.

### Features

- Senses Ambient Light and Provides an Output Current Proportional to the Ambient Light Intensity
- Photopic Spectral Response
- Dynamic Dark Current Compensation
- Two Selectable Output Current Gain Modes
- Power Down Mode
- Less than 18  $\mu$ A at 100 lux Active Power Consumption in Normal Operation (Less than 8  $\mu$ A at Dark)
- Less than 200 pA Quiescent Power Dissipation in Power Down Mode at All Light Levels
- Linear Response Over the Full Operating Range
- Senses Intensity of Ambient Light from ~0 lux to Over 100,000 lux
- Wide Operating Voltage Range (2 V to 5.5 V)
- Wide Operating Temperature Range (-40°C to 85°C)
- Drop-in Replacement Device in 1.6 x 1.6 mm Package
- These Devices are Pb-Free, Halogen Free/BFR Free and are RoHS Compliant

### Applications

- Saves display power in applications such as:
  - ♦ Cell Phones, PDAs, MP3 players, GPS
  - ♦ Cameras, Video Recorders
  - ♦ Mobile Devices with Displays or Backlit Keypads
  - ♦ Laptops, Notebooks, Digital Signage
  - ♦ LCD TVs and Monitors, Digital Picture Frames
  - ♦ Automobile Dashboard Displays and Infotainment
  - ♦ LED Indoor/Outdoor Residential and Street Lights

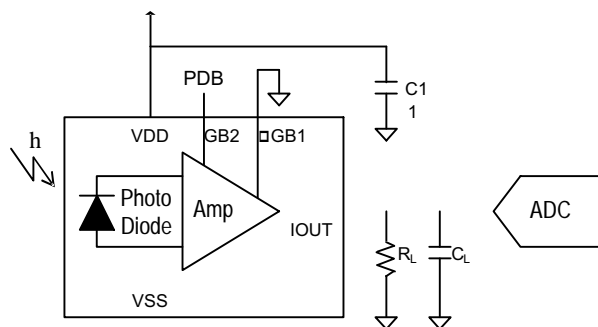

Figure 1. Typical Application Circuit

# NOA1211

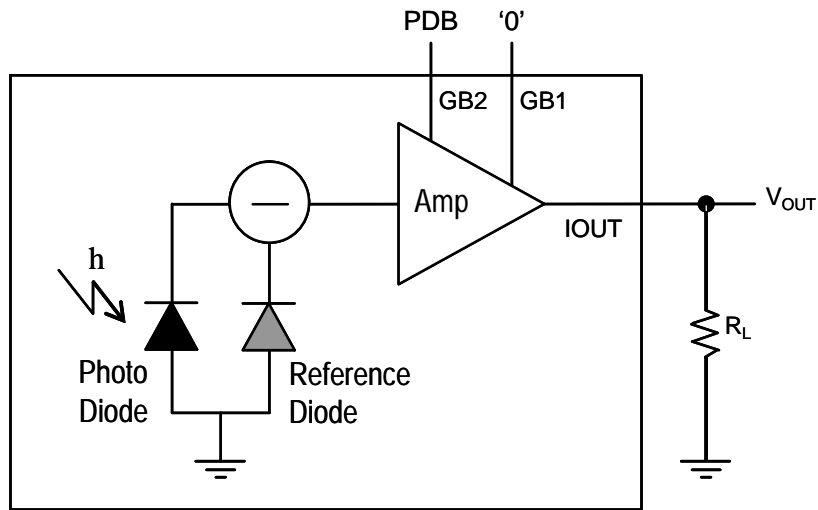

Figure 2. Simplified Block Diagram Configured for M-Gain and Power-Down





TYPICAL CHARACTERISTICS

Figure 9. Output Current vs. Angle (End View, Normalized, Medium Gain Mode)

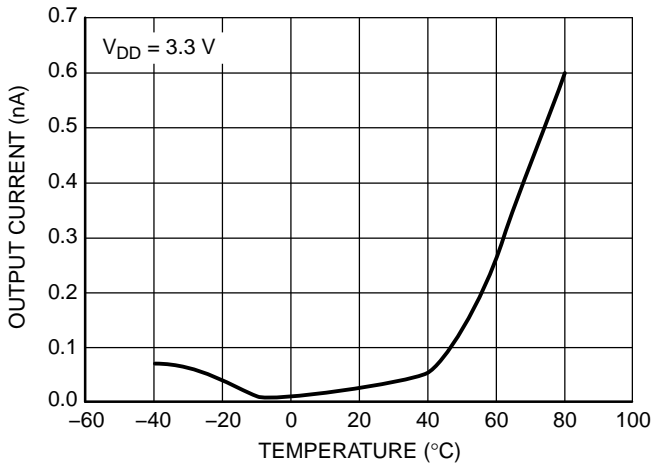

Figure 11. Output Current at 0 lux vs. Temperature (Medium Gain)

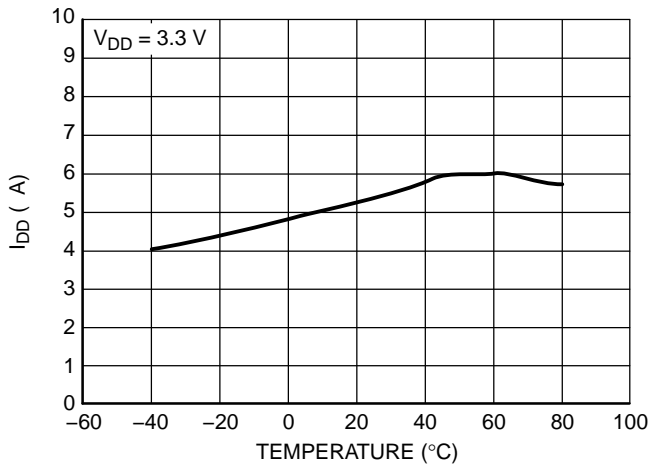

Figure 13. Supply Current at 0 lux vs. Temperature (Medium Gain)

Figure 10. Output Current vs. Angle (End View, Normalized, Medium Gain Mode)

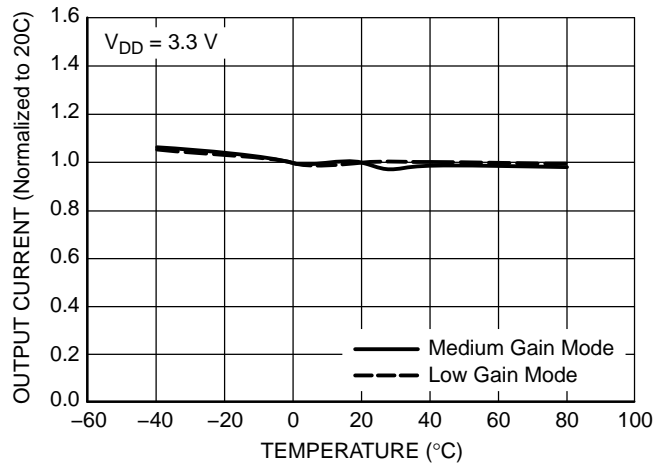

Figure 12. Output Current at 100 lux vs. Temperature (Medium Gain)

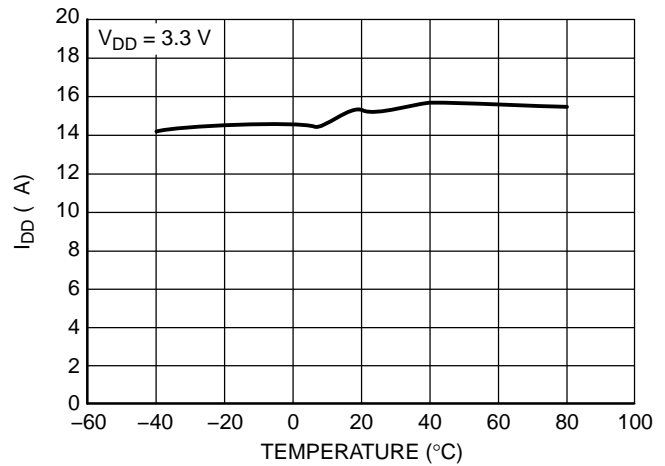

Figure 14. Supply Current at 100 lux vs. Temperature (Medium Gain)

# NOA1211

## TYPICAL CHARACTERISTICS



V

**Figure 15. Output Current at 100 lux vs. Supply Voltage (Medium Gain)**

**Figure 16. Supply Current vs.  $E_v$  (Medium Gain)**

**Figure 17. Supply Current vs. Supply Voltage (Medium Gain)**

# NOA1211

## DESCRIPTION OF OPERATION

### Ambient Light Sensor Architecture

The NOA1211 employs a sensitive photo diode fabricated in ON Semiconductor's standard CMOS process technology. The major components of this sensor are as shown in Figure 2 . The photons which are to be detected pass through an ON Semiconductor proprietary color filter limiting extraneous photons and thus performing as a band pass filter on the incident wave front. The filter only

transmits photons in the visible spectrum which are primarily detected by the human eye and exhibits excellent

NOTES:  
1. DIMENSIONING AND TOLERANCING PER ASME  
Y14.5M, 1994.

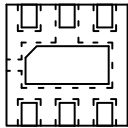
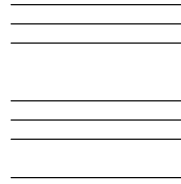
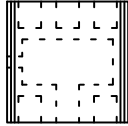



**onsemi**, **onsemi**, and other names, marks, and brands are registered and/or common law trademarks of Semiconductor Components Industries, LLC dba "**onsemi**" or its affiliates and/or subsidiaries in the United States and/or other countries. **onsemi** owns the rights to a number of patents, trademarks, copyrights, trade secrets, and other intellectual property. A listing of **onsemi**'s product/patent coverage may be accessed at [www.onsemi.com/site/pdf/Patent-Marking.pdf](http://www.onsemi.com/site/pdf/Patent-Marking.pdf). **onsemi** reserves the right to make changes at any time to any products or information herein, without notice. The information herein is provided "as-is" and **onsemi** makes no warranty, representation or guarantee regarding the accuracy of the information, product features, availability, functionality, or suitability of its products for any particular purpose, nor does **onsemi** assume any liability arising out of the application or use of any product or circuit, and specifically disclaims any and all liability, including without limitation special, consequential or incidental damages. Buyer is responsible for its products and applications using **onsemi**

---

---