



Figure 1. Functional Block Diagram

# NCT203

**Table 2. ABSOLUTE MAXIMUM RATINGS** (Note 1)

Rating	Symbol	Value	Unit
Supply Voltage ( $V_{DD}$ ) to GND	$V_{DD}$	-0.3, +3	V
SCL, SDA, ALERT, THERM		-0.3 to +5.25	V
Input current on SDA, THERM	$I_{IN}$	-1, +50	mA
Maximum Junction Temperature	$T_{J(max)}$	150.7	°C
Operating Temperature Range	TOP	-40 to 125	°C
Storage Temperature Range	$T_{STG}$	-65 to 160	°C
ESD Capability, Human Body Model (Note 2)	ESD <sub>HBM</sub>	2000	V
ESD Capability, Machine Model (Note 2)	ESD <sub>MM</sub>	100	V

Stresses exceeding Maximum Ratings may damage the device. Maximum Ratings are stress ratings only. Functional operation above the Recommended Operating Conditions is not implied. Extended exposure to stresses above the Recommended Operating Conditions may affect device reliability.

# NCT203

**Table 4. ELECTRICAL CHARACTERISTICS**

( $T_A = T_{MIN}$  to  $T_{MAX}$ ,  $V_{DD} = 1.6$  V to 2.75 V. All specifications for  $-40^{\circ}\text{C}$  to  $+125^{\circ}\text{C}$ , unless otherwise noted.)

Parameter	Test Conditions	Min	Typ	Max	Unit
-----------	-----------------	-----	-----	-----	------

**TEMPERATURE SENSOR**

Measurement Range		-40		+125	$^{\circ}\text{C}$
-------------------	--	-----	--	------	--------------------

**TEMPERATURE SENSOR ACCURACY**

$V_{DD}$	$T_A = 25^{\circ}\text{C}$ to $85^{\circ}\text{C}$
	$T_A = -40$

### Theory of Operation

The NCT203 is an on-chip temperature sensor and over/under temperature alarm. When the NCT203 is operating normally, the on-board ADC operates in a free running mode. The ADC digitizes the signals from the temperature sensor and the results are stored in the temperature value register.

The measurement results are compared with the corresponding high, low, and THERM temperature limits, stored in the on-chip registers. Out-of-limit comparisons generate flags that are stored in the status register. A result that exceeds the high temperature limit or the low temperature limit causes the ALERT output to assert. Exceeding the THERM temperature limits causes the THERM output to assert low. The ALERT output can be reprogrammed as a second THERM output.

The limit registers are programmed and the device controlled and configured via the serial I<sup>2</sup>C. The contents of any register are also read back via the I<sup>2</sup>C. Control and configuration functions consist of switching the device between normal operation and standby mode, selecting the temperature measurement range, masking or enabling the ALERT output, switching Pin 6 between ALERT and THERM2, and selecting the conversion rate.

### Temperature Measurement Method

A simple method of measuring temperature is to exploit the negative temperature coefficient of a diode, measuring the base emitter voltage ( $V_{BE}$ ) of a transistor operated at constant current. However, this technique requires calibration to null the effect of the absolute value of  $V_{BE}$ , which varies from device to device.

The technique used in the NCT203 measures the change in  $V_{BE}$  when the device operates at different currents.

To measure  $\Delta V_{BE}$ , the operating current through the sensor is switched among related currents.  $N1 \times I$  and  $N2 \times I$  are different multiples of the current,  $I$ . The currents through the temperature diode are switched between  $I$  and  $N1 \times I$ , giving  $\Delta V_{BE1}$ ; and then between  $I$  and  $N2 \times I$ , giving  $\Delta V_{BE2}$ . The temperature is then calculated using the two  $\Delta V_{BE}$  measurements.

The resulting  $\Delta V_{BE}$  waveforms are passed through a 65 kHz low-pass filter to remove noise and then to a chopper-stabilized amplifier. This amplifies and rectifies the waveform to produce a dc voltage proportional to  $\Delta V_{BE}$ . The ADC digitizes this voltage producing a temperature

measurement. To reduce the effects of noise, digital filtering is performed by averaging the results of 16 measurement cycles for low conversion rates. At rates of 16-, 32- and 64-conversions/second, no digital averaging occurs. Signal conditioning and measurement of the internal temperature sensor are performed in the same manner.

### Temperature Measurement Results

The results of the temperature measurement are stored in the temperature value register and compared with limits programmed into the high and low limit registers.

The temperature value is in Register 0x00 and has a resolution of 1°C.

### Temperature Measurement Range

The temperature measurement range is, by default, 0°C to +127°C. However, the NCT203 can be operated using an extended temperature range. The extended measurement range is -64°C to +191°C. Therefore, the NCT203 can be used to measure the full temperature range of the NCT203, from -40°C to +125°C.

The extended temperature range is selected by setting Bit 2 of the configuration register to 1. The temperature range is 0°C to 127°C when Bit 2 equals 0. A valid result is available in the next measurement cycle after changing the temperature range.

In extended temperature mode, the upper and lower temperature that can be measured by the NCT203 is limited by the device temperature range of -40°C to +125°C. The temperature register can have values from -64°C to +191°C.

It should be noted that although temperature 40°C to +125°C.

The extended temperature range is selected by setting Bit 2 of the configuration register to 1. A valid result is available in the next measurement cycle after changing the temperature range.

Table 5. TEMPERATURE DATA FORMAT

Temperature	Binary	Offset Binary (Note 1)
-55°C	0 000 0000 (Note 2)	0 000 1001
0°C	0 000 0000	0 100 0000
+1°C	0 000 0001	0 100 0001
+10°C	0 000 1010	0 100 1010
+25°C	0 001 1001	0 101 1001

Conversion Rate Register

**Table 8. STATUS REGISTER BIT ASSIGNMENTS**

Bit	Name	Function
7	BUSY	1 when ADC is converting
6	HIGH (Note 4)	1 when high temperature limit is tripped
5	LOW (Note 4)	1 when low temperature limit is tripped
4	Reserved	
3	Reserved	
2	Reserved	
1	Reserved	
0	THRM	1 when THERM limit is tripped

4. These flags stay high until the status register is read or they are reset by POR unless Pin 6 is configured as THERM2. Then, only Bit 2 remains high until the status register is read or is reset by POR.

**One-Shot Register**

The one-shot register is used to initiate a conversion and comparison cycle when the NCT203 is in standby mode, after which the device returns to standby. Writing to the one-shot register address (0x0F) causes the NCT203 to perform a conversion and comparison on the temperature. This is not a data register as such, and it is the write operation to Address 0x0F that causes the one-shot conversion. The data written to this address is irrelevant and is not stored.

**Table 10. LIST OF REGISTERS**

Read Address (Hex)	Write Address (Hex)	Name	Power-On Default
Not Applicable	Not Applicable	Address Pointer	Undefined
00	Not Applicable	Temperature Value	0000 0000 (0x00)
02	Not Applicable	Status	Undefined
03	09	Configuration	0000 0000 (0x00)
04	0A	Conversion Rate	0000 1000 (0x08)
05	0B	Temperature High Limit	0101 0101 (0x55) (85°C)
06	0C	Temperature Low Limit	0000 0000 (0x00) (0°C)
Not Applicable	0F (Note 1)	One-Shot	
20	20	THERM Limit	0101 0101 (0x55) (85°C)
21	21	THERM Hysteresis	0000 1010 (0x0A) (0x10°C)
22	22	Consecutive ALERT	0000 0001 (0x01)
FE	Not Applicable	Manufacturer ID	0001 1010 (0x1A)
FF	Not Applicable	Die Revision Code	0xXX

**Consecutive ALERT Register**

The value written to this register determines how many out-of-limit measurements must occur before an ALERT is generated. The default value is that one out-of-limit measurement generates an ALERT. The maximum value that can be chosen is 4. The purpose of this register is to allow the user to perform some filtering of the output. This is particularly useful at the fastest three conversion rates, where no averaging takes place. This register is at Address 0x22.

**Table 9. CONSECUTIVE ALERT REGISTER CODES**

Register Value	Number of Out-of-Limit Measurements Required
yxxx 000x	1
yxxx 001x	2
yxxx 011x	3
yxxx 111x	4

Note: x = don't care bits, and y = Bus timeout bit. Default = 0. See interface section for more information.



### SERIAL INTERFACE

Control of the NCT203 is carried out via the I<sup>2</sup>C compatible serial interface. The NCT203 is connected to this bus as a slave device, under the control of a master device.

The NCT203 has a bus timeout feature. When this is enabled, the bus times out after typically 25 ms of no activity. After this time, the NCT203 resets the SDA line back to its idle state (high impedance) and waits for the next start condition. However, this feature is not enabled by

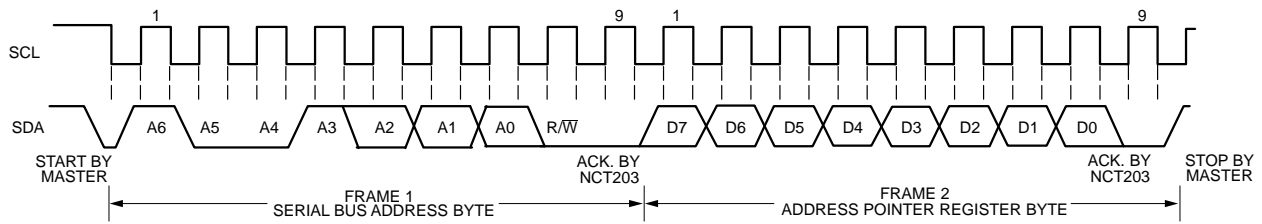

Figure 4. Writing to the Address Pointer Register

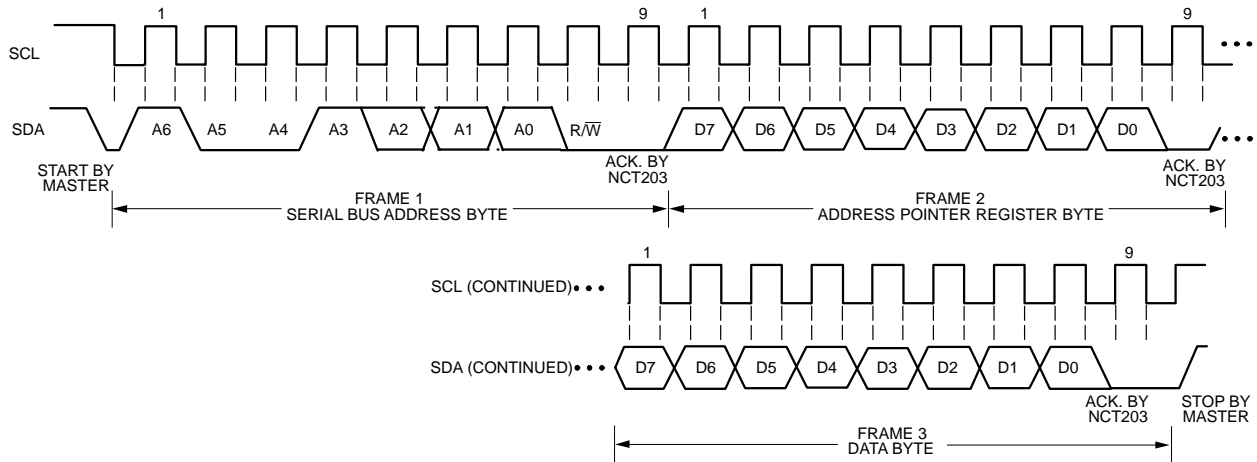

Figure 5. Writing a Register Address to the Address Pointer Register, then Writing a Single Byte of Data to a Register

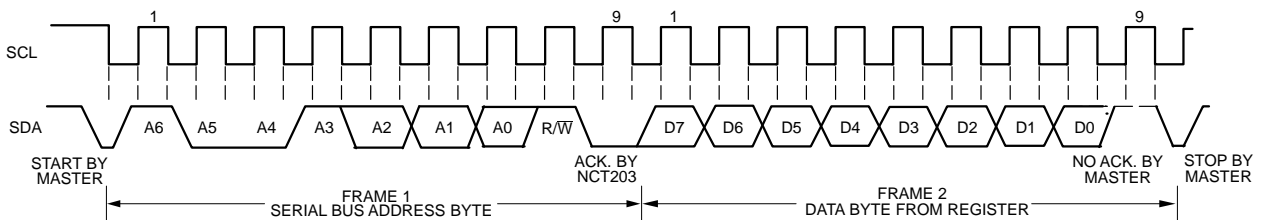

Figure 6. Reading a Byte of Data from a Register

**ALERT Output**

This is applicable when Pin 6 is configured as an  $\overline{\text{ALERT}}$  output. The  $\overline{\text{ALERT}}$  output goes low whenever an out-of-limit measurement is detected. It is an open-drain output and requires a pullup resistor to  $V_{DD}$ . Several  $\overline{\text{ALERT}}$  outputs can be wire-OR'ed together, so that the common line goes low if one or more of the  $\overline{\text{ALERT}}$  outputs goes low.

The  $\overline{\text{ALERT}}$  output can be used as an interrupt signal to a processor, or as an  $\overline{\text{SMBALERT}}$ . Slave devices on the bus cannot normally signal to the bus master that they want to talk, but the  $\overline{\text{SMBALERT}}$  function allows them to do so.

One or more  $\overline{\text{ALERT}}$  outputs can be connected to a common  $\overline{\text{SMBALERT}}$  line that is connected to the master. When the  $\overline{\text{SMBALERT}}$  line is pulled low by one of the devices, the following procedure occurs (see Figure 7):

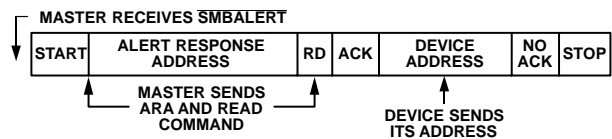

Figure 7. Use of  $\overline{\text{SMBALERT}}$

1.  $\overline{\text{SMBALERT}}$  is pulled low.
2. Master initiates a read operation and sends the alert response address (ARA = 0001 100). This is a general call address that must not be used as a specific device address.
3. The device whose  $\overline{\text{ALERT}}$  output is low responds to the alert response address and the master reads its device address. As the device address is seven bits, an LSB of 1 is added. The address of the device is now known and it can be interrogated in the usual way.
4. If more than one device's  $\overline{\text{ALERT}}$  output is low, the one with the lowest device address takes

## NCT203

priority, in accordance with normal bus arbitration. Once the NCT203 has responded to the alert response address, it resets its  $\overline{\text{ALERT}}$  output, provided that the error condition that caused the  $\overline{\text{ALERT}}$  no longer exists. If the  $\overline{\text{SMBALERT}}$  line remains low, the master sends the ARA again, and so on until all devices whose  $\overline{\text{ALERT}}$  outputs were low have responded.

### **Low Power Standby Mode**

The NCT203 can be put into low power standby mode by setting

In this example, the  $\overline{\text{THERM2}}$  limits are set lower than the  $\overline{\text{THERM}}$  limits. The  $\overline{\text{THERM2}}$  output is used to turn on a fan. If the temperature continues to rise and exceeds the  $\overline{\text{THERM}}$  limits, the  $\overline{\text{THERM}}$  output provides additional cooling by throttling the CPU.

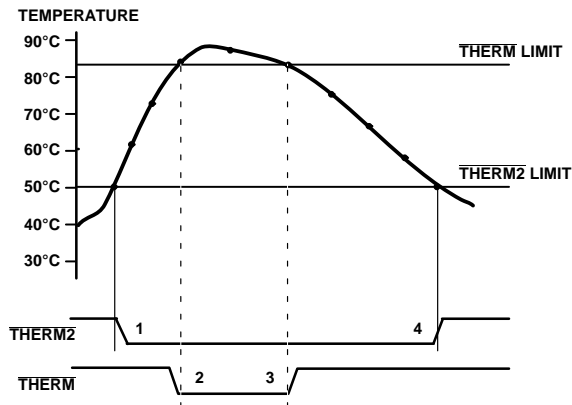

Figure 9. Operation of the  $\overline{\text{THERM}}$  and  $\overline{\text{THERM2}}$  Interrupts

- When the  $\overline{\text{THERM2}}$  limit is exceeded, the  $\overline{\text{THERM2}}$  signal asserts low.
- If the temperature continues to increase and exceeds the  $\overline{\text{THERM}}$  limit, the  $\overline{\text{THERM}}$  output asserts low.
- The  $\overline{\text{THERM}}$  output deasserts (goes high) when the temperature falls to  $\overline{\text{THERM}}$  limit minus hysteresis. In Figure 9, there is no hysteresis value shown.

WDFN8 2x1.8, 0.5P  
CASE 511BU  
ISSUE O

DATE 18 JAN 2012

SCALE 4:1

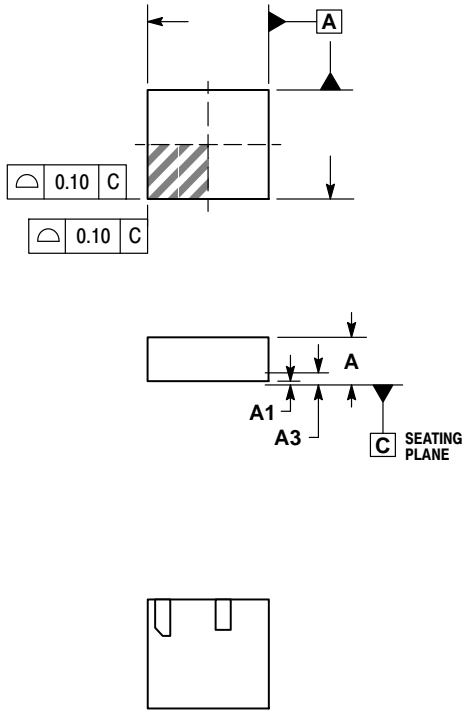

DIM	MILLIMETERS	
	MIN	MAX
A		

**onsemi**, **onsemi**, and other names, marks, and brands are registered and/or common law trademarks of Semiconductor Components Industries, LLC dba "**onsemi**" or its affiliates and/or subsidiaries in the United States and/or other countries. **onsemi** owns the rights to a number of patents, trademarks, copyrights, trade secrets, and other intellectual property. A listing of **onsemi**'s product/patent coverage may be accessed at [www.onsemi.com/site/pdf/Patent-Marking.pdf](http://www.onsemi.com/site/pdf/Patent-Marking.pdf). **onsemi** reserves the right to make changes at any time to any products or information herein, without notice. The information herein is provided "as-is" and **onsemi** makes no warranty, representation or guarantee regarding the accuracy of the information, product features, availability, functionality, or suitability of its products for any particular purpose, nor does **onsemi** assume any liability arising out of the application or use of any product or circuit, and specifically disclaims any and all liability, including without limitation special, consequential or incidental damages. Buyer is responsible for its products and applications using **onsemi**

---

---