

NCS2584

Four-Channel Video Driver with Load Detection and Signal Detection

The NCS2584 is a 4 channel high speed video driver with 6th order Butterworth Reconstruction filters on each channel. A first set of 3 channel has High Definition (HD) 34 MHz filters, one per channel. A fourth channel offers an extra driver for Cvbs type video signal with an 8 MHz filter. The NCS2584 is in fact a combination of a triple HD video driver plus a single Cvbs video driver.

In addition, this four channel video driver integrates an auto shutdown function in order to detect the moment when the DAC is turned on or off. It also embeds a load detection to lower the power consumption when the TV is unplugged. To further reduce the layout and software complexity, the NCS2584 will automatically turn off without any external command. These features help significantly the systems like Blu Ray™ players or Set Top Boxes to be in line with the restricting energy saving standards on standby modes.

It is designed to be compatible with Digital to Analog Converters (DAC) embedded in most video processors.

All channels can accept DC or AC coupled signals. In case of AC coupled inputs, the internal clamps are enabled. The outputs can drive both AC and DC coupled 150 Ω loads but also two loads of 150 Ω in parallel.

Features

- 3 High Definition Filters with 6th Order Butterworth Filter and 34 MHz Bandwidth for YPbPr 1080i
- One Cvbs Driver Including 6th Order Butterworth 8 MHz Filter
- Integrated Automatic Shutdown Function to Improve Power Consumption Savings When the DAC is Off
- Integrated Load Detection for TV Presence
- Low Pin Count for Layout Simplification
- Internal Fixed Gain: 6 dB ± 0.2
- AC or DC Coupled Inputs and Outputs
- Each channel Capable to Drive 2 Loads of 150 Ω in Parallel
- Operating Supply Voltage Range: +3.3 V and 5.0 V
- TSSOP14 Package
- These Devices are Pb Free, Halogen Free/BFR Free and are RoHS Compliant

Typical Application

- Set Top Box Decoder
- DVD and Blu Ray Player / Recorder
- HDTV, Home Theatre



<http://onsemi.com>

MARKING DIAGRAM

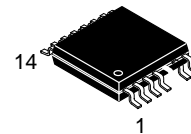

TSSOP-14

A, AA = Assembly Location
Y = Year
W = Work Week
▪ = Pb-Free Package

NCS2584

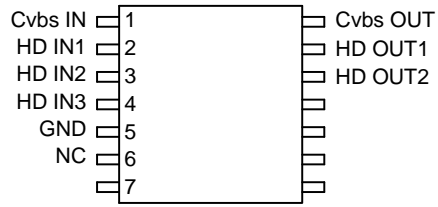

Figure 1. Pinouts

NCS2584

TSSOP-14 PIN DESCRIPTION

Pin No.	Name	Type	Description
1	Cvbs IN	Input	Cvbs Input Channel
2	HD IN1	Input	High Definition Input 1
3	HD IN2	Input	High Definition Input 2
4	HD IN3	Input	High Definition Input 3
5	GND	Ground	Ground
6	NC	NC	No Connection
7	NC	NC	No Connection
8	NC	NC	No Connection
9	NC	NC	No Connection
10	VCC	Power	Power Supply 3.3 V or 5 V
11	HD OUT3	Output	High Definition Output 3
12	HD OUT2	Output	High Definition Output 2
13	HD OUT1	Output	High Definition Output 1
14	Cvbs OUT	Output	Cvbs Output Channel

MAXIMUM RATINGS

Rating	Symbol	Value	Unit
Power Supply Voltages	V_{CC}	$-0.3 \leq V_{CC} \leq 5.5$	Vdc
Input Voltage Range	$V_{I/O}$	$-0.3 \leq V_I \leq V_{CC}$	Vdc
Input Differential Voltage Range	V_{ID}	$-0.3 \leq V_I \leq V_{CC}$	Vdc
Output Current (Indefinitely) per Channel	I_O	40	mA
Maximum Junction Temperature (Note 1)	T_J	150	°C
Operating Ambient Temperature	T_A	-40 to +85	°C
Storage Temperature Range	T_{stg}	-60 to +150	°C
Thermal Resistance, Junction-to-Air	$R_{\theta JA}$	125	°C/W
ESD Protection Voltage (HBM)	V_{esd}	6000	V

Stresses exceeding Maximum Ratings may damage the device. Maximum Ratings are stress ratings only. Functional operation above the Recommended Operating Conditions is not implied. Extended exposure to stresses above the Recommended Operating Conditions may affect device reliability.

1. Power dissipation must be considered to ensure maximum junction temperature (T_J) is not exceeded.

Maximum Power Dissipation

The maximum power that can be safely dissipated is limited by the associated rise in junction temperature. For the plastic packages, the maximum safe junction temperature is 150°C. If the maximum is exceeded momentarily, proper circuit operation will be restored as soon as the die temperature is reduced. Leaving the device in the “overheated” condition for an extended period can result in device burnout. To ensure proper operation, it is important to observe the derating curves.

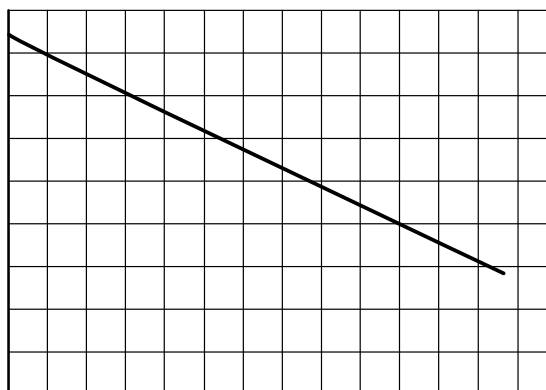

Figure 3. Power Dissipation vs Temperature

NCS2584

DC ELECTRICAL CHARACTERISTICS ($V_{CC} = +3.3\text{ V}$, $T_A = 25^\circ\text{C}$; unless otherwise specified)

Symbol	Characteristics	Conditions	Min	Typ	Max	Unit
--------	-----------------	------------	-----	-----	-----	------

POWER SUPPLY

I_{CC}	All channel Loaded 150 Ω , signal on all inputs, including the load current			73	120	mA
$I_{CC\ sh1}$	Shutdown current, no load, no input signal			5	10	μA
$I_{CC\ sh2}$	Shutdown current, no load, with input signal on all inputs			9	40	μA
$I_{CC\ SD}$	Only the SD channel loaded 150 Ω , signal on all inputs			20		mA
$I_{CC\ HD}$	Only the 3 HD channels loaded 150 Ω , signal on all inputs			53		mA

DC PERFORMANCE

V_{cm}	Input Common Mode Voltage Range	$V_{CC} = 3.3\text{ V or }5\text{ V}$	GND
----------	---------------------------------	---------------------------------------	-----

NCS2584

AC ELECTRICAL CHARACTERISTICS FOR HIGH DEFINITION CHANNELS ($V_{CC} = +3.3\text{ V}$, $V_{in} = 1\text{ V}_{PP}$, $R_{source} = 75\ \Omega$, $T_A = 25^\circ\text{C}$, inputs AC-coupled with $0.1\ \mu\text{F}$, all outputs AC-coupled with $220\ \mu\text{F}$ into $150\ \Omega$ referenced to 400 kHz ; unless otherwise specified)

Symbol	Characteristics	Conditions	Min	Typ	Max	Unit
A_{VHD}	Voltage Gain	$V_{in} = 1\text{ V}$ - All HD Channels	5.8	6.0	6.2	dB
BW_{HD}	Low Pass Filter Bandwidth	-1 dB (Note 4) -3 dB	26 30	31 34		MHz
A_{RHD}	Stop-band Attenuation	@ 44.25 MHz @ 74.25 MHz (Note 4)	8 33	15 42		dB
THD_{HD}	Total Harmonic Distortion	$V_{out} = 1.4\text{ V}_{PP}$ @ 10 MHz $V_{out} = 1.4\text{ V}_{PP}$ @ 15 MHz $V_{out} = 1.4\text{ V}_{PP}$ @ 20 MHz		0.4 0.6 0.8		%

NO

NCS2584

DC ELECTRICAL CHARACTERISTICS ($V_{CC} = +5\text{ V}$, $T_A = 25$)

NCS2584

AC ELECTRICAL CHARACTERISTICS FOR HIGH DEFINITION CHANNELS ($V_{CC} = 5\text{ V}$, $V_{in} = 1\text{ V}_{PP}$, $R_{source} = 75\ \Omega$, $T_A = 25^\circ\text{C}$, inputs AC-coupled with 0.1

NCS2584

TYPICAL CHARACTERISTICS

$V_{CC} = +3.3\text{ V}$, $V_{in} = 1\text{ V}_{PP}$, $R_{source} = 75\ \Omega$, $T_A = 25^\circ\text{C}$, Inputs AC-coupled with $0.1\ \mu\text{F}$, All Outputs AC-coupled with $220\ \mu\text{F}$ into $150\ \Omega$
Referenced to 400 kHz; unless otherwise specified

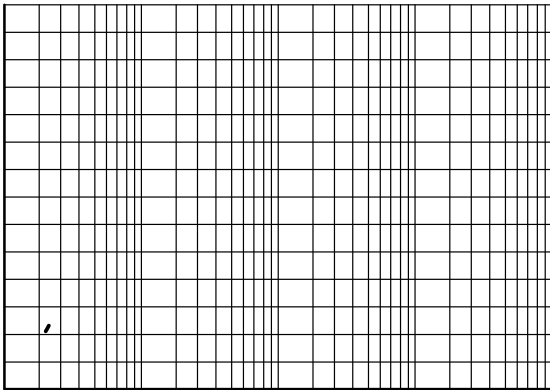

TYPICAL CHARACTERISTICS

$V_{CC} = +3.3\text{ V}$, $V_{in} = 1\text{ V}_{PP}$, $R_{source} = 75\ \Omega$, $T_A = 25^\circ\text{C}$, Inputs AC-coupled with $0.1\ \mu\text{F}$, All Outputs AC-coupled with $220\ \mu\text{F}$ into $150\ \Omega$
 Referenced to 400 kHz; unless otherwise specified

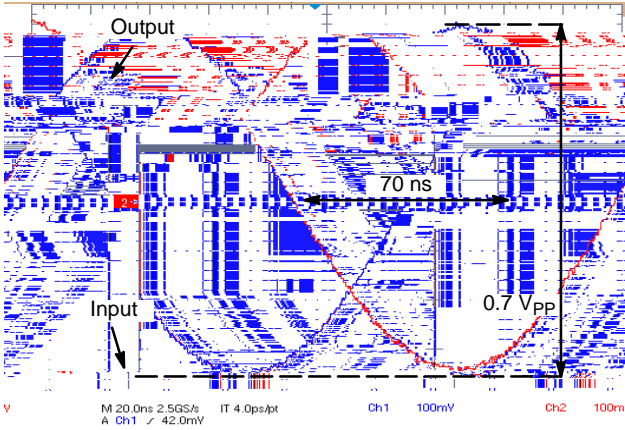

Figure 8. SD Propagation Delay

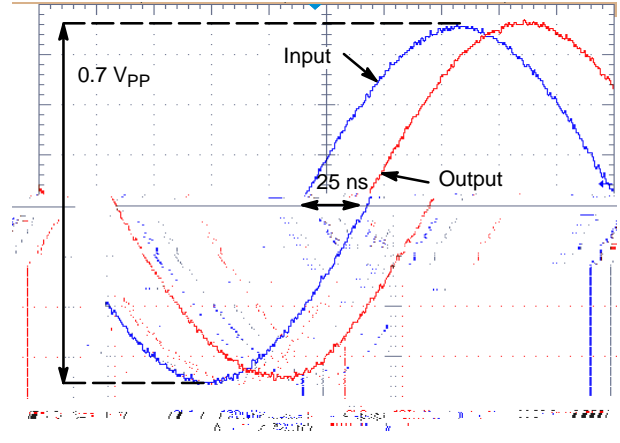

Figure 9. HD Propagation Delay

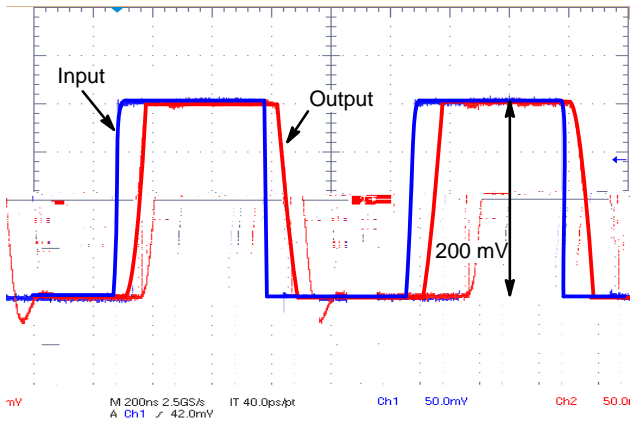

Figure 10. SD Small Signal Response

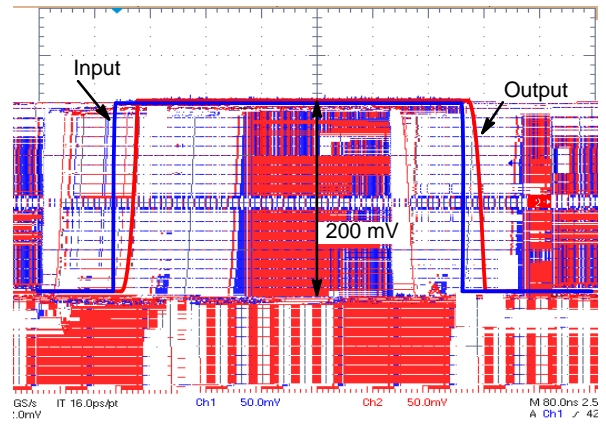

Figure 11. HD Small Signal Response

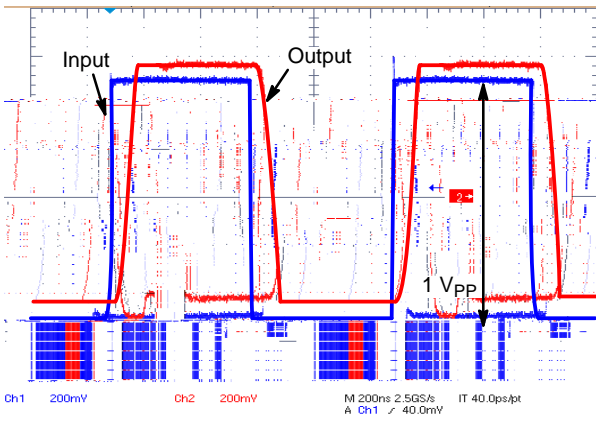

Figure 12. SD Large Signal Response

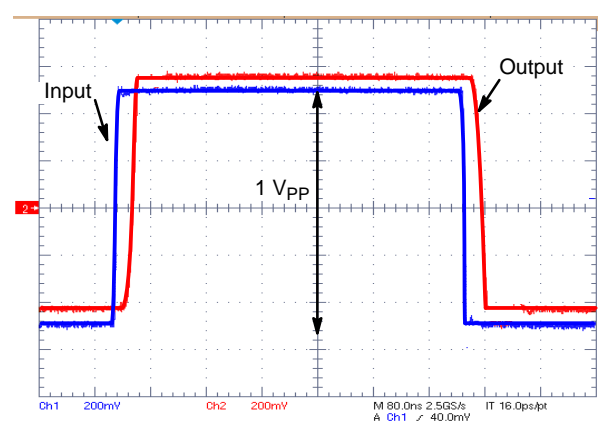

Figure 13. HD Large Signal Response

APPLICATIONS INFORMATION

The NCS2584 quad video driver has been optimized for Standard and High Definition video applications covering the requirements of the standards Composite video (Cvbs), Component Video (720p/1080i). The three HD channels have 34 MHz filters to cover high definition like video applications. A fourth channel implements one standard definition filter of 8 MHz bandwidth to drive the Cvbs signal.

In the regular mode of operation, each channel provides an internal voltage to voltage gain of 2 from input to output. This effectively reduces the number of external components required as compared to discrete approach

implemented with stand alone op amps. An internal level shifter is employed shifting up the output voltage by adding an offset of 280 mV on the outputs. This prevents sync pulse clipping and allows DC coupled output to the 150 Ω video load. In addition, the NCS2584 integrates a 6th order Butterworth filter for each. This allows rejection of the aliases or unwanted over-sampling effects produced by the video DAC. Similarly for the case of DVD recorders which use a ADC, this anti aliasing filter (reconstruction filter) will avoid picture quality issue and will help filtration of parasitic signals caused by EMI interference.

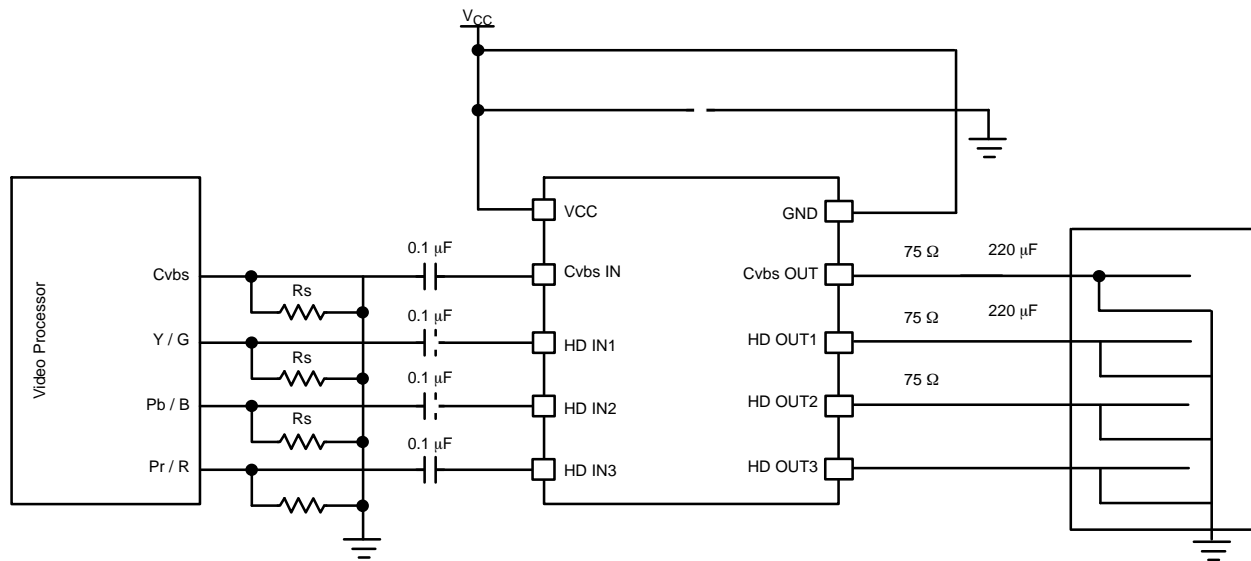

Figure 19. AC-Coupled Configuration at the Input and Output



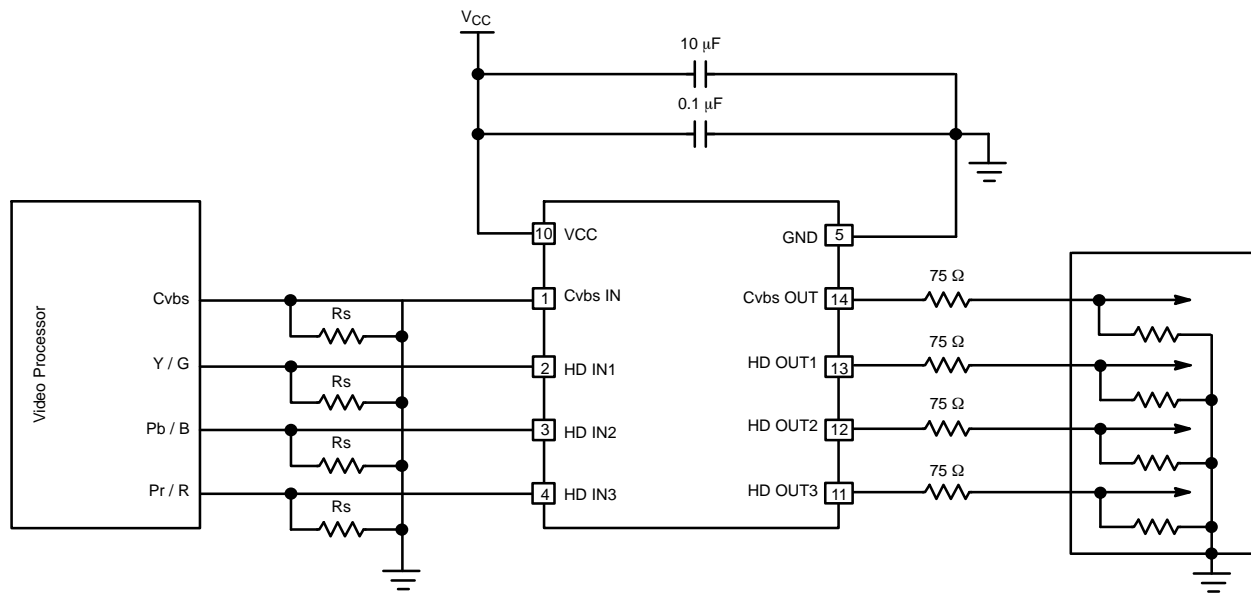

Figure 22. DC-Coupled Inputs and Outputs

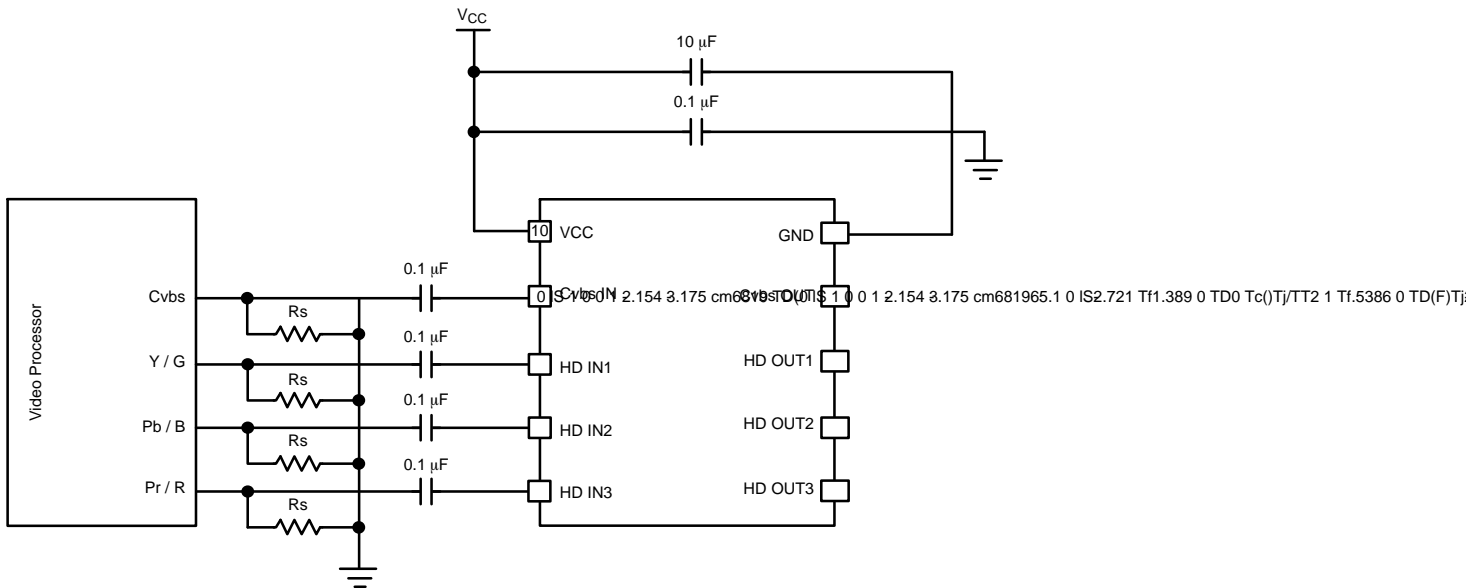

Figure 23. NCS2584 Driving 2 Loads in Parallel for SCART Applications

NCS2584

Video Driving Capability

With an output current capability of 40 mA the NCS2584 was designed to be able to drive at least two video display loads in parallel. This type of application is illustrated in Figure 23. Figure 24 (multiburst) and Figure 25 (linearity) show that the video signal can efficiently drive a 75 Ω equivalent load and not degrade the video performance.

ESD Protection

All the device pins are protected against electrostatic discharge at a level of 6 kV following HBM JEDEC standards. This feature has been considered with a particular attention with ESD structure able to sustain the typical values requested by the systems like Set Top Boxes or Blue Ray players. This parameter is particularly important for video driver which usually constitutes the last stage in the video chain before the video output connector.

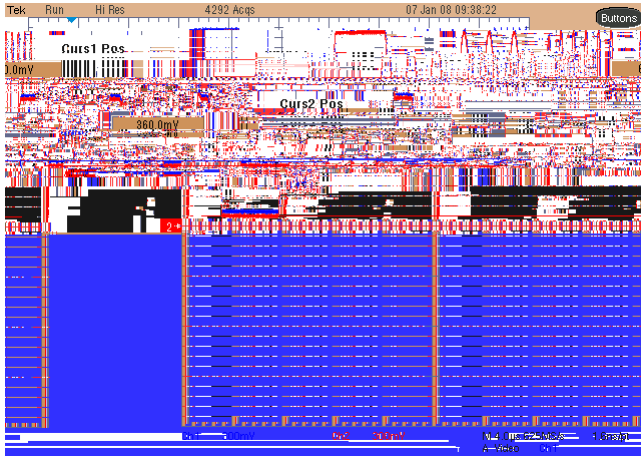

Figure 24. Multiburst Test with Two 150 Ω Loads

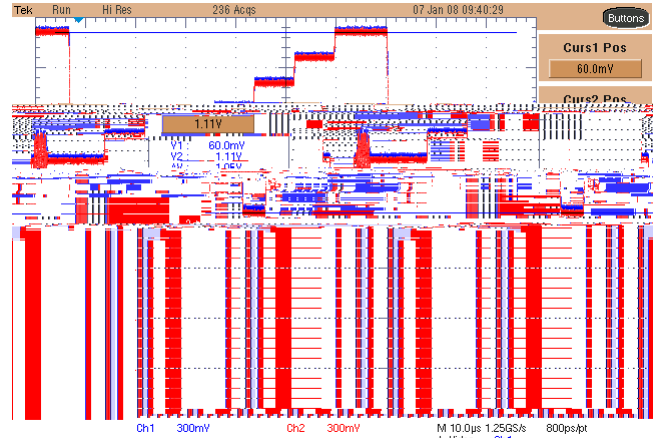

Figure 25. Linearity Test with Two 150 Ω Loads

ORDERING INFORMATION

Device	Package	Shipping†
NCS2584DTBR2G	TSSOP-14 (Pb-Free)	2500 / Tape & Reel

†For information on tape and reel specifications, including part orientation and tape sizes, please refer to our Tape and Reel Packaging Specifications Brochure, BRD8011/D.

onsemi, **onsemi**, and other names, marks, and brands are registered and/or common law trademarks of Semiconductor Components Industries, LLC dba "**onsemi**" or its affiliates and/or subsidiaries in the United States and/or other countries. **onsemi** owns the rights to a number of patents, trademarks, copyrights, trade secrets, and other intellectual property. A listing of **onsemi**'s product/patent coverage may be accessed at www.onsemi.com/site/pdf/Patent-Marking.pdf. **onsemi** reserves the right to make changes at any time to any products or information herein, without notice. The information herein is provided "as-is" and **onsemi** makes no warranty, representation or guarantee regarding the accuracy of the information, product features, availability, functionality, or suitability of its products for any particular purpose, nor does **onsemi** assume any liability arising out of the application or use of any product or circuit, and specifically disclaims any and all liability, including without limitation special, consequential or incidental damages. Buyer is responsible for its products and applications using **onsemi**
