

# NCP81381

## Intelligent and MOSFET

The NCP81381 integrates a MOSFET driver, high-side MOSFET and low-side MOSFET into a single package.

The driver and MOSFETs have been optimized for high-current DC-DC buck power conversion applications. The NCP81381 integrated solution greatly reduces package parasitics and board space compared to a discrete component solution.

### Features

- Capable of Average Currents up to 25 A
- Capable of Switching at Frequencies up to 2 MHz
- Capable of Peak Currents up to 60 A
- Compatible with 3.3 V or 5 V PWM Input
- Responds Properly to 3-level PWM Inputs
- Option for Zero Cross Detection with 3-level PWM
- ZCD\_EN Input for Diode Emulation with 2-level PWM
- Internal Bootstrap Diode
- Undervoltage Lockout
- Supports Intel® Power State 4
- Thermal Warning output
- Thermal Shutdown
- This is a Pb-Free Device

### Applications

- Desktop & Notebook Microprocessors

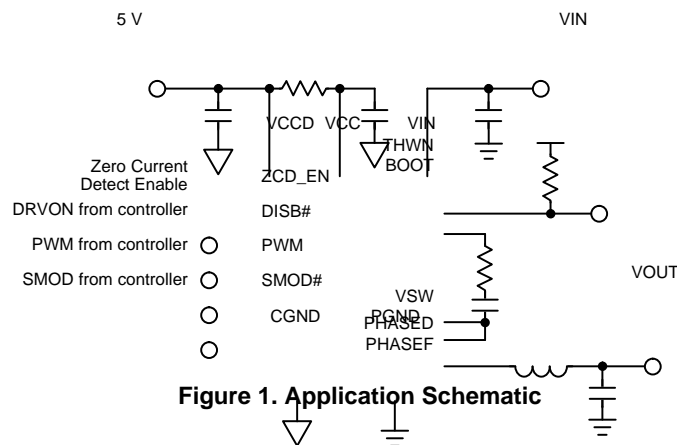

[www.onsemi.com](http://www.onsemi.com)

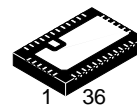

QFN36 6x4  
CASE 485DZ

### MARKING DIAGRAM

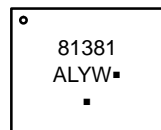

A = Assembly Location  
L = Wafer Lot  
Y = Year  
W = Work Week  
▪ = Pb-Free Package

(Note: Microdot may be in either location)

### PINOUT DIAGRAM

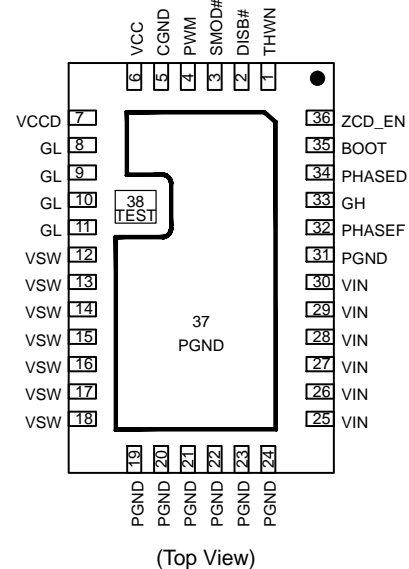

### ORDERING INFORMATION

Device	Package	Shipping†
NCP81381MNTXG	QFN36 (Pb-Free)	2500 / Tape & Reel

†For information on tape and reel specifications, including part orientation and tape sizes, please refer to our Tape and Reel Packaging Specification Brochure, BRD8011/D.

# NCP81381

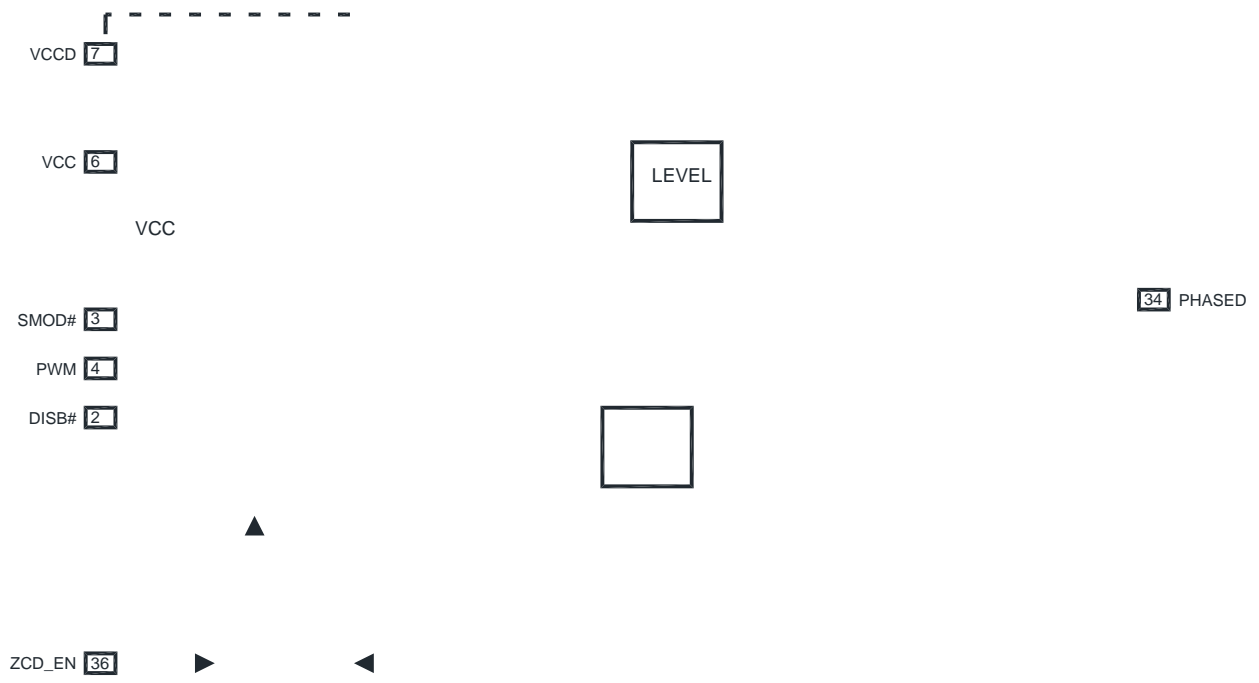

Figure 2. Block Diagram

# NCP81381

## PIN LIST AND DESCRIPTIONS (continued)

Pin No.	Symbol	Description
19	PGND	

# NCP81381

## THERMAL INFORMATION

Rating	Symbol	Value	Unit
Thermal Resistance	$\theta_{JA}$	22	°C/W
	$R\Psi_{J-BT}$	2.0	°C/W
	$R\Psi_{J-CT}$	4.0	°C/W

# NCP81381

## ELECTRICAL CHARACTERISTICS (continued)

( $V_{VCC} = V_{VCCD} = 5.0\text{ V}$ ,  $V_{VIN} = 12\text{ V}$ ,  $V_{DISB\#} = 2.0\text{ V}$ ,  $C_{VCCD} = C_{VCC} = 0.1\text{ }\mu\text{F}$  unless specified otherwise) Min/Max values are valid for the temperature range  $-10^{\circ}\text{C} \leq T_A \leq 100^{\circ}\text{C}$  unless noted otherwise, and are guaranteed by test, design or statistical correlation.

Parameter	Symbol	Conditions	Min	Typ	Max	Unit
-----------	--------	------------	-----	-----	-----	------

### VCCD SUPPLY CURRENT

Operating		DISB# = 5 V, ZCD_EN = 5 V, PWM = 400 kHz	–	–	15	mA
Enabled, No switching		DISB# = 5 V, PWM = 0 V, $V_{PHASED} = 0\text{ V}$	–	175	300	$\mu\text{A}$
Disabled		DISB# = 0 V	–	0.1	1	$\mu\text{A}$

### DISB# INPUT

Input Resistance		To Ground, @ 25°C	–	461	–	k $\Omega$
Upper Threshold	$V_{UPPER}$		–	–	2.0	V
Lower Threshold	$V_{LOWER}$		0.8	–	–	V
Hysteresis		$V_{UPPER} - V_{LOWER}$	200	–	–	mV
Enable Delay Time	$t_{ENABLE}$	Time from DISB# transitioning HI to when VSW responds to PWM.	–	–	40	$\mu\text{s}$
Disable Delay Time	$t_{DISABLE}$	Time from DISB# transitioning LOW to when both output FETs are off.	–	25	50	ns

### PWM INPUT

Input High Voltage	$V_{PWM\_HI}$		2.65	–	–	V
Input Mid-state Voltage	$V_{PWM\_MID}$		1.4	–	2.0	V
Input Low Voltage	$V_{PWM\_LO}$		–	–	0.7	V
Input Resistance	$R_{PWM\_HIZ}$	SMOD# = $V_{SMOD\#\_HI}$ or $V_{SMOD\#\_LO}$	10	–	–	M $\Omega$
Input Resistance	$R_{PWM\_BIAS}$	SMOD# = $V_{SMOD\#\_MID}$	–	63	–	k $\Omega$
PWM Input Bias Voltage	$V_{PWM\_BIAS}$	SMOD# = $V_{SMOD\#\_MID}$	–	1.7	–	V
PWM Propagation Delay, Rising	$t_{pd\_GL}$	PWM = 2.25 V to GL = 90%; SMOD# = LOW	–	25	35	ns
PWM Propagation Delay, Falling	$t_{pd\_GH}$	PWM = 0.75 V to GH = 90%	–	15	25	ns
Exiting PWM Mid-state Propagation Delay, Mid-to-Low	$T_{PWM\_EXIT\_L}$	PWM = Mid-to-Low to GL = 10%, ZCD_EN = High	–	13	25	ns
Exiting PWM Mid-state Propagation Delay, Mid-to-High	$T_{PWM\_EXIT\_H}$	PWM = Mid-to-High to GH = 10%	–	13	25	ns

### SMOD# INPUT

SMOD# Input Voltage High	$V_{SMOD\_HI}$		2.65	–	–	V
SMOD# Input Voltage Mid-state	$V_{SMOD\#\_MID}$		1.4	–	2.0	V
SMOD# Input Voltage Low	$V_{SMOD\_LO}$		–	–	0.7	V
SMOD# Input Resistance	$R_{SMOD\#\_UP}$	Pull-up resistance to VCC	–	440	–	k $\Omega$
SMOD# Propagation Delay, Falling	$T_{SMOD\#\_PD\_F}$	SMOD# = Low to GL = 90%, PWM = Low	–	26	30	ns
SMOD# Propagation Delay, Rising	$T_{SMOD\#\_PD\_R}$	SMOD# = High to GL = 10%, ZCD_EN = High, PWM = Low	–	15	30	ns

### ZCD\_EN INPUT

ZCD_EN Input Voltage High	$V_{ZCD\_EN\_HI}$
---------------------------	-------------------

# NCP81381

## ELECTRICAL CHARACTERISTICS (continued)

( $V_{VCC} = V_{VCCD} = 5.0\text{ V}$ ,  $V_{VIN} = 12\text{ V}$ ,  $V_{DISB\#} = 2.0\text{ V}$ ,  $C_{VCCD} = C_{VCC} = 0.1\text{ }\mu\text{F}$  unless specified otherwise) Min/Max values are valid for the

# NCP81381

Table 1. LOGIC TABLE

INPUT TRUTH TABLE					
DISB#	PWM	SMOD# (Note 5)	ZCD_EN	GH	GL
L	X	X	X	L	L
H	H	X	X	H	L
H	L	X	L	L	L
H	L	X	H	L	H
H	MID	H or MID	H	L	ZCD (Note 6)
H	MID	X	L	L	L (Note 7)
H	MID	L	X	L	L (Note 7)

5. PWM input is driven to mid-state with internal divider resistors when SMOD# is driven to mid-state and PWM input is undriven externally.

6. GL goes low following 80 ns de-bounce time, 250 ns blanking time and then SW exceeding ZCD threshold.

7. There is no delay before GL goes low.



Figure 4. Efficiency – 12 V Input, 1.2 V Output, 500 kHz



Figure 5. Efficiency – 19 V Input, 1.2 V Output, 500 kHz





If  $V_{SMOD\#\_LO} < SMOD\# < V_{SMOD\#\_HI}$  (Mid-State), internal resistances will set undriven PWM pin voltage to Mid-State.

**Disable Input (DISB#)**

The DISB# pin is used to disable the GH to the High-Side FET to prevent power transfer. The pin has a pull-down resistance to force a disabled state when it is left unconnected. DISB# can be driven from the output of a logic device or set high with a pull-up resistance to VCC.

**VCC Undervoltage Lockout**

The VCC pin is monitored by an Undervoltage Lockout Circuit (UVLO). VCC voltage above the rising threshold enables the NCP81381.

**Table 2. UVLO/DISB# LOGIC TABLE**

UVLO	DISB#	Driver State
L	X	Disabled (GH = GL = 0)
H	L	Disabled (GH = GL = 0)
H	H	Enabled (See Table x)
H	Open	Disabled (GH = GL = 0)

**Thermal Warning/Thermal Shutdown Output**

The THWN pin is an open drain output. When the temperature of the driver exceeds  $T_{THWN}$ , the THWN pin will be pulled low indicating a thermal warning. At this point, the part continues to function normally. When the temperature drops  $T_{THWN\_HYS}$  below  $T_{THWN}$ , the THWN pin will go high. If the driver temperature exceeds  $T_{THDN}$ , the part will enter thermal shutdown and turn off both MOSFETs. Once the temperature falls  $T_{THDN\_HYS}$  below  $T_{THDN}$ , the part will resume normal operation.

**Skip Mode Input (SMOD#)**

The SMOD# tri-state input pin has an internal pull-up resistance to VCC. When driven high, the SMOD# pin enables the low side synchronous MOSFET to operate independently of the internal ZCD function. When the SMOD# pin is set low during the PWM cycle it disables the low side MOSFET to allow discontinuous mode operation.

The NCP81381 has the capability of internally connecting a resistor divider to the PWM pin. To engage this mode, SMOD# needs to be placed into mid-state. While in SMOD# mid-state, the IC logic is equivalent to SMOD# being in the high state.

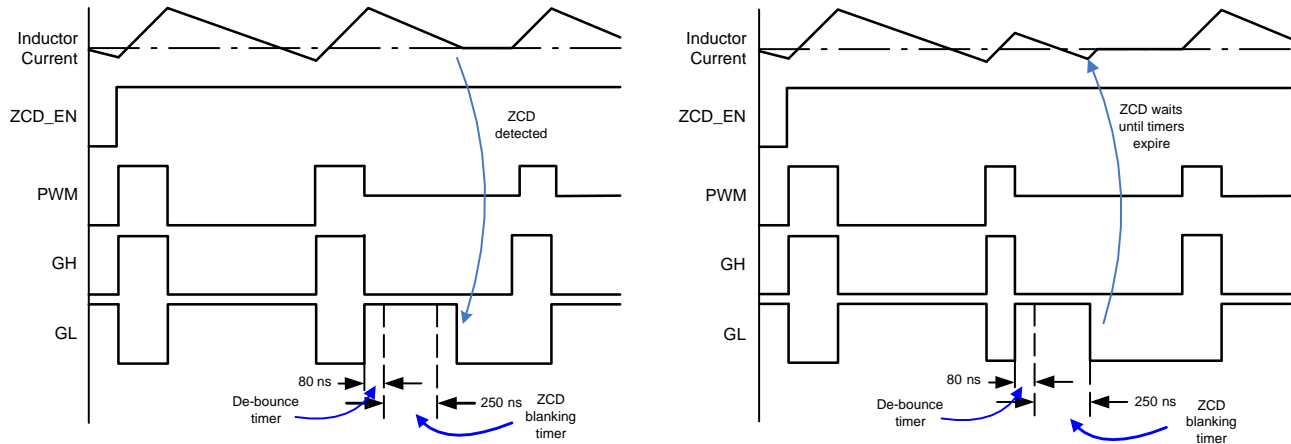
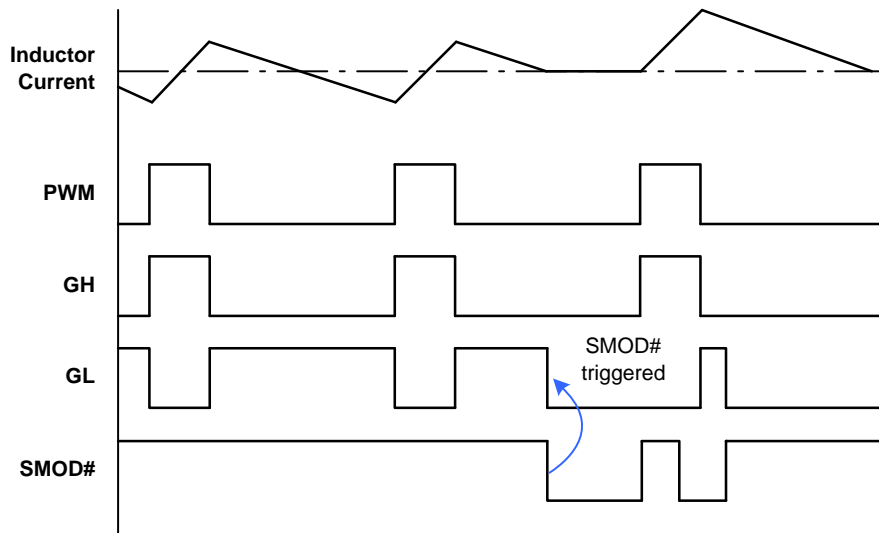

**Figure 6. PWM Timing Diagram**

NOTES: If the Zero Current Detect circuit detects zero current after the ZCD Wait timer period, the GL is driven low by the Zero Current Detect signal.

If the Zero Current Detect circuit detects zero current before the ZCD Wait timer period has expired, the Zero Current detect signal is ignored and the GL is driven low at the end of the ZCD Wait timer period.

# NCP81381



**Figure 7. SMOD# Timing Diagram**

NOTE: If the SMOD# input is driven low at any time after the GL has been driven high, the SMOD# Falling edge will trigger the GL to go low.  
 If the SMOD# input is driven low while the GH is high, the SMOD# input is ignored.

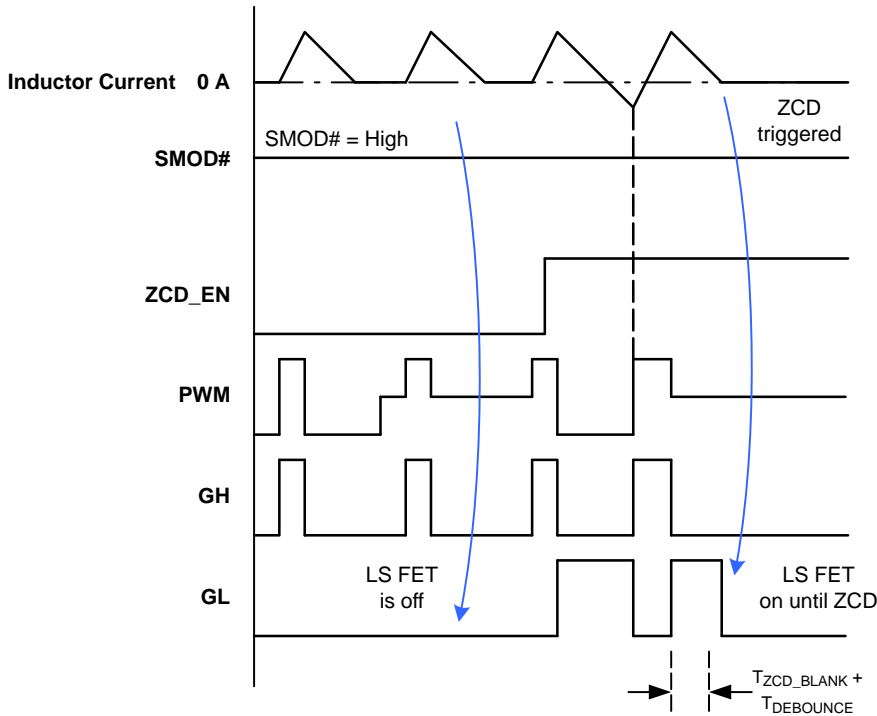

**Figure 8. ZCD\_EN Timing Diagram**

NOTE: When ZCD is enabled by pulling ZCD\_EN# high, the NCP81381 keeps the LS FET on until it detects zero current, reducing power loss.

# NCP81381

For Use with Controllers with 3-State PWM and No Zero Current Detection Capability:

Table 3. LOGIC TABLE – 3-STATE PWM CONTROLLERS WITH NO ZCD

PWM
-----

# NCP81381

For Use with Controllers with 3-state PWM and Zero Current Detection Capability:

**Table 4. LOGIC TABLE – 3-STATE PWM CONTROLLERS WITH ZCD**

PWM	SMOD#	ZCD_EN	GH	GL
H	L	H	ON	OFF
M	L	H	OFF	OFF
L	L	H	OFF	ON

This section describes operation with controllers that are capable of 3 PWM output levels and have zero current detection during discontinuous conduction mode (DCM).

The SMOD# pin needs to be pulled low (below  $V_{SMOD\#\_LO}$ ).

The ZCD\_EN pin needs to either be set to 5 V or left



Recommended PCB Layout  
(viewed from top)

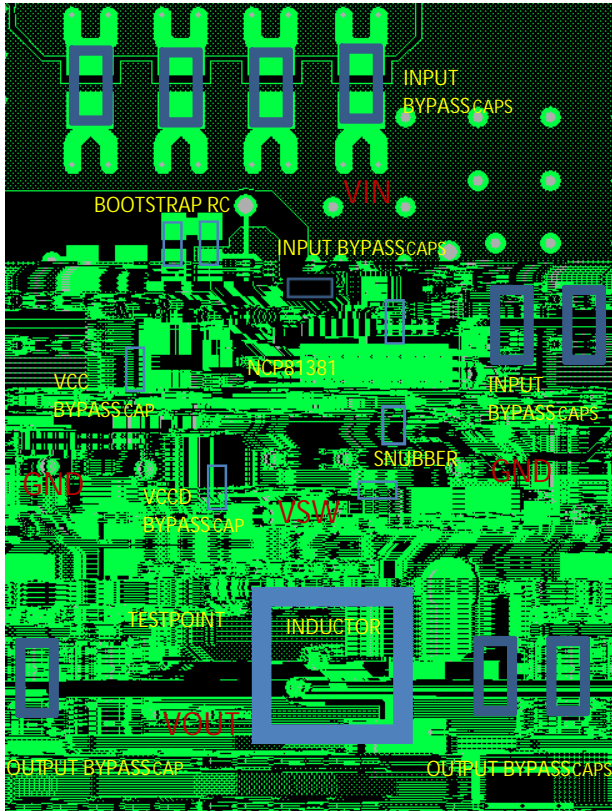

Figure 12. Top Copper Layer

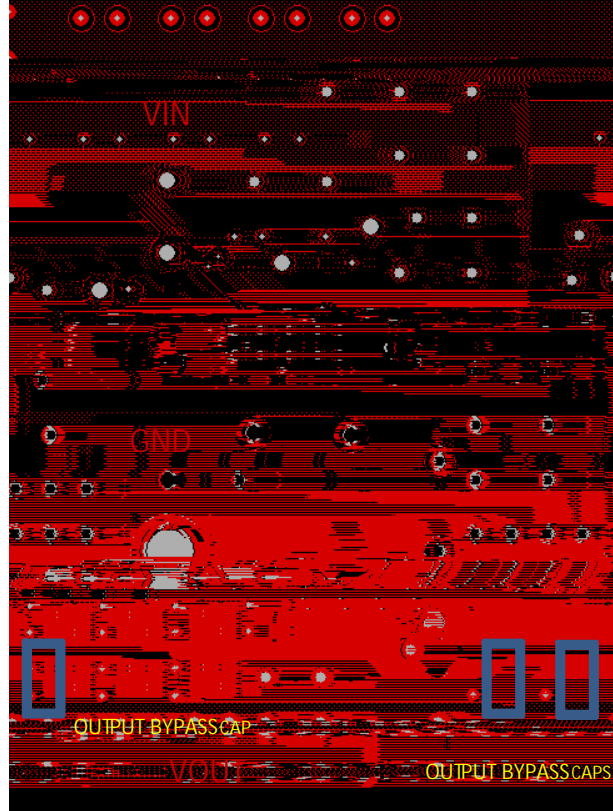

Figure 13. Bottom Copper Layer

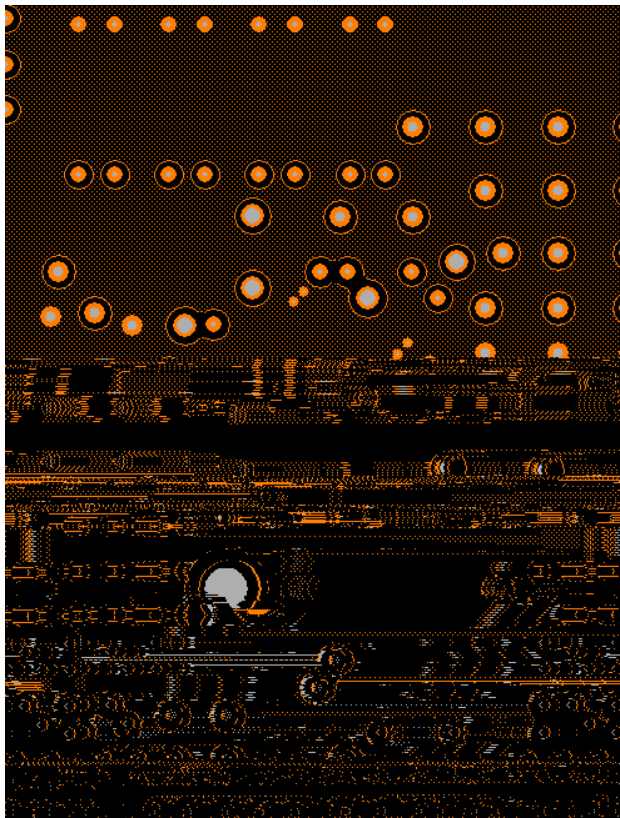

Figure 14. Layer 2 Copper Layer (Ground Plane)

Intel is a registered trademark of Intel Corporation in the U.S. and/or other countries.

**QFN36 6x4, 0.4P**  
**CASE 485DZ**  
**ISSUE A**

DATE 19 JUN 2015

1 36  
**SCALE 2:1**

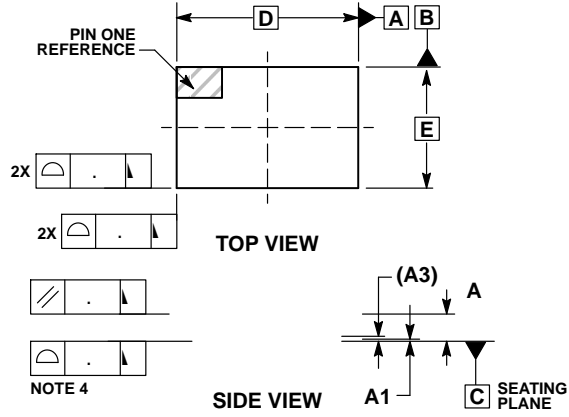

- NOTES:
1. DIMENSIONING AND TOLERANCING PER ASME Y14.5M, 1994.
  2. CONTROLLING DIMENSION: MILLIMETERS.
  3. DIMENSION b APPLIES TO PLATED TERMINAL AND IS MEASURED BETWEEN 0.15 AND 0.25 MM FROM THE TERMINAL TIP.
  4. COPLANARITY APPLIES TO THE EXPOSED PAD AS WELL AS THE TERMINALS.

MILLIMETERS		
DIM	MIN	MAX
A	0.90	1.20
A1	0.00	0.05
A3	0.20	REF
b	0.15	0.25
D	6.00	BSC
D2	4.95	5.05

E	4.00	BSC
E2	2.44	2.54

e	0.40	BSC
G	0.52	0.62

\*For additional information on our Pb-Free strategy and soldering details, please download the

**onsemi**, **onsemi**, and other names, marks, and brands are registered and/or common law trademarks of Semiconductor Components Industries, LLC dba "**onsemi**" or its affiliates and/or subsidiaries in the United States and/or other countries. **onsemi** owns the rights to a number of patents, trademarks, copyrights, trade secrets, and other intellectual property. A listing of **onsemi**'s product/patent coverage may be accessed at [www.onsemi.com/site/pdf/Patent-Marking.pdf](http://www.onsemi.com/site/pdf/Patent-Marking.pdf). **onsemi** reserves the right to make changes at any time to any products or information herein, without notice. The information herein is provided "as-is" and **onsemi** makes no warranty, representation or guarantee regarding the accuracy of the information, product features, availability, functionality, or suitability of its products for any particular purpose, nor does **onsemi** assume any liability arising out of the application or use of any product or circuit, and specifically disclaims any and all liability, including without limitation special, consequential or incidental damages. Buyer is responsible for its products and applications using **onsemi**

---

---