

e

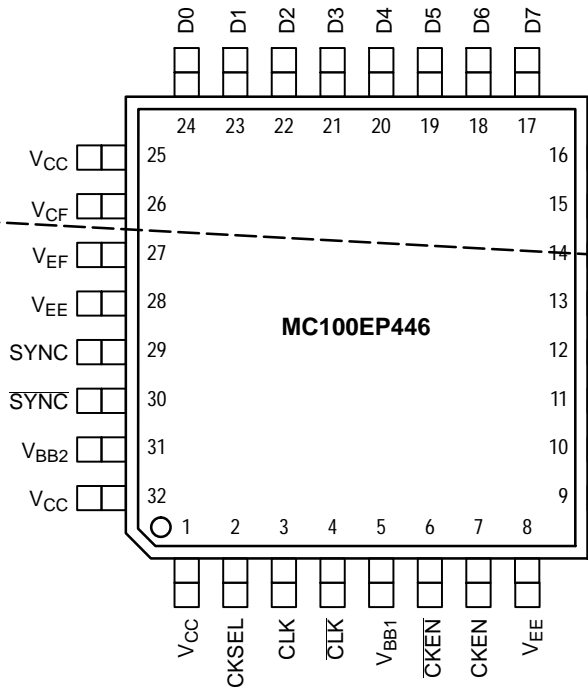

MC100EP446



Warning: All V_{CC} and V_{EE} pins must be externally connected to Power Supply to guarantee proper operation.

Figure 1. LQFP-32 Pinout (Top View)

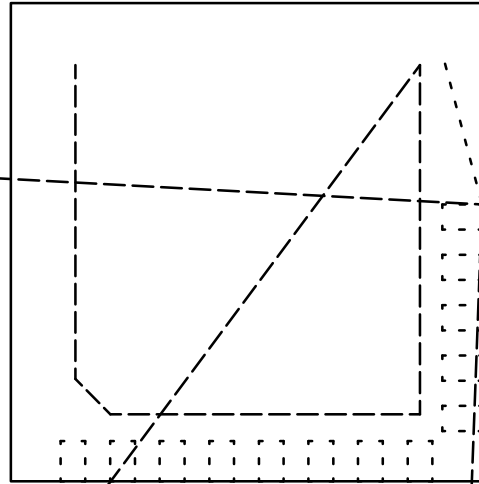
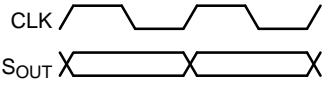



Figure 2. QFN-32 Pinout (Top View)

MC100EP446

Table 2. TRUTH TABLE

Pin	Function	
	HIGH	LOW
CKSEL	S _{OUT} : PCLK = 8:1 CLK: S _{OUT} = 1:1 	S _{OUT} : PCLK = 8:1 CLK: S _{OUT} = 1:2 
CKEN	Synchronously Disables Normal Parallel to Serial Conversion	Synchronously Enables Normal Parallel to Serial Conversion
SYNC	Asynchronously Resets Internal Flip-Flops*	Synchronous Enable

*The rising edge of SYNC will asynchronously reset the internal circuitry. The falling edge of the SYNC followed by the falling edge of CLK initiates the conversion process synchronously on the next rising edge of CLK.

Table 3. INPUT VOLTAGE LEVEL SELECTION TABLE

Input Function	Connect To V _{CF} Pin
ECL Mode	V _{EF} Pin
CMOS Mode	No Connect
TTL Mode*	1.5 V ± 100 mV

*For TTL Mode, if no external voltage can be provided, the reference voltage can be provided by connecting the appropriate resistor between V_{CF} and V_{EE} pins.

Table 4. DATA INPUT OPERATING VOLTAGE TABLE

Power Supply (V _{CC} , V _{EE})	Data Inputs (D [0:7])			
	CMOS	TTL	PECL	NECL
PECL	✓	✓	✓	N/A
NECL	N/A	N/A	N/A	✓

Power Supply	Resistor Value 10% (Tolerance)
3.3 V	1.5 kΩ
5.0 V	500 Ω

MC100EP446

MC100EP446

Table 5. ATTRIBUTES

Characteristics	Value
Internal Input Pulldown Resistor	75 kΩ
Internal Input Pullup Resistor	

MC100EP446

Table 7. 100EP DC CHARACTERISTICS, PECL $V_{CC} = 3.3\text{ V}$, $V_{EE} = 0\text{ V}$ (Note 2)

Symbol	Characteristic	-40°C			25°C			85°C			Unit
		Min	Typ	Max	Min	Typ	Max	Min	Typ	Max	
I_{EE}	Power Supply Current	90	110	130	90	110	130	95	115	135	mA
V_{OH}	Output HIGH Voltage (Note 3)	2155	2280	2405	2155	2280	2405	2155	2280	2405	mV
V_{OL}	Output LOW Voltage (Note 3)	1305	1480	1605	1305	1480	1605	1305	1480	1605	mV
V_{IH}	Input HIGH Voltage (Single-Ended)										
	CMOS	2000		3300	2000		3300	2000		3300	mV
	PECL	2075		3300	2075		3300	2075		3300	
V_{IL}	Input LOW Voltage (Single-Ended)										
	CMOS	0		800	0		800	0		800	mV
	PECL	1305		1675	1305		1675	1305		1675	
V_{IL}	TTL	0		800	0		800	0		800	
V_{BB}	Output Voltage Reference	1775	1875	1975	1775	1875	1975	1775	1875	1975	mV
V_{IHCMR}	Input HIGH Voltage Common Mode Range (Differential Configuration) (Note 4)	2.0		3.3	2.0		3.3	2.0		3.3	V
I_{IH}	Input HIGH Current			150			150			150	μA
I_{IL}	Input LOW Current	0.5			0.5			0.5			μA

MC100EP446

Table 8. 100EP DC CHARACTERISTICS, PECL $V_{CC} = 5.0\text{ V}$, $V_{EE} = 0\text{ V}$ (Note 5)

Symbol	Characteristic	-40°C			25°C			85°C			Unit
		Min	Typ	Max	Min	Typ	Max	Min	Typ	Max	
I_{EE}	Power Supply Current	90	110	130	90	110	130	95	115	135	mA
V_{OH}	Output HIGH Voltage (Note 6)	3855	3980	4105	3855	3980	4105	3855	3980	4105	mV
V_{OL}	Output LOW Voltage (Note 6)	3005	3180	3305	3005	3180	3305	3005	3180	3305	mV
V_{IH}	Input HIGH Voltage (Single)										

MC100EP446

Table 10. AC CHARACTERISTICS $V_{CC} = 0\text{ V}$; $V_{EE} = -3.0\text{ V}$ to -5.5 V or $V_{CC} = 3.0\text{ V}$ to 5.5 V ; $V_{EE} = 0\text{ V}$ (Note 11)

Symbol	Characteristic	-40°C			25°C			85°C			Unit
		Min	Typ	Max	Min	Typ	Max	Min	Typ	Max	
f _{max}	Maximum Frequency (Figure 15)										GHz
	CKSEL High	3.2	3.4		3.2	3.4		3.2	3.4		
	CKSEL Low	1.6	1.7		1.6	1.7		1.6	1.7		
t _{PLH} , t _{PHL}	Propagation Delay to Output Differential CKSEL = 0 CLK TO S _{OUT}										

MC100EP446

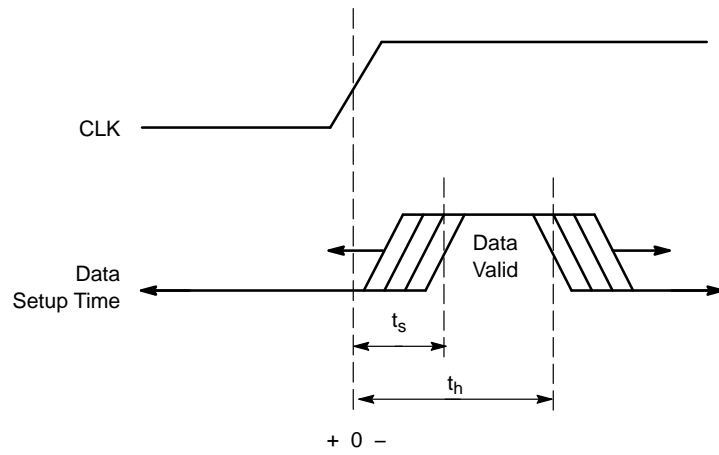

Figure 4. Setup and Hold Time for Data

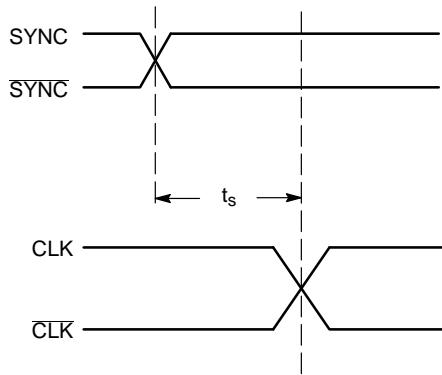

Figure 5. Setup Time for SYNC

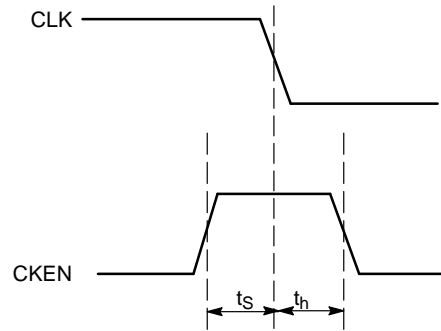

Figure 6. Setup and Hold Time for CKEN

MC100EP446

MC100EP446

Similarly, for CKSEL HIGH operation, the time from when the parallel data is latched ① to when the data is seen on the S_{OUT} ② is on the rising edge of the 14th clock cycle plus internal propagation delay (Figure 8). Furthermore, the PCLK switches on the rising edge of CLK.

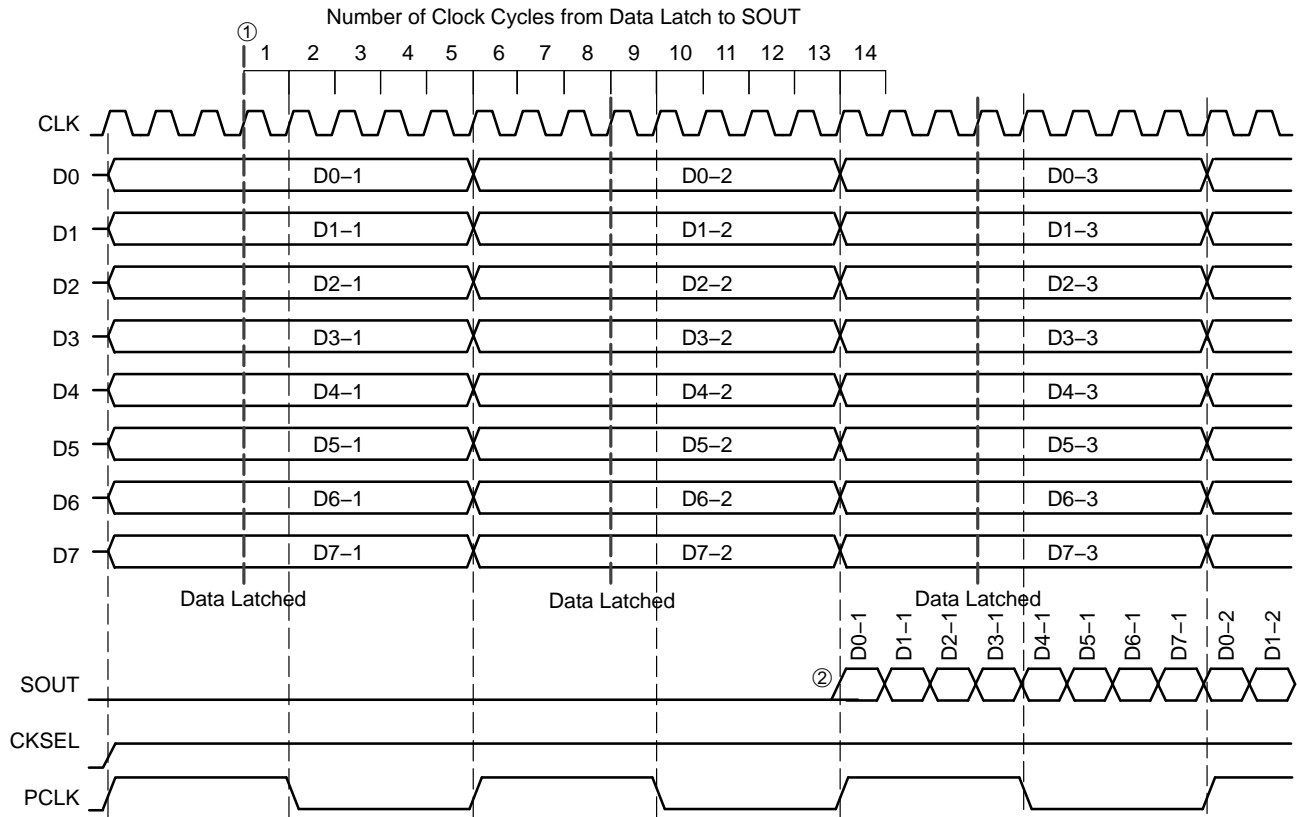

Figure 8. Timing Diagram 1:8 Parallel to Serial Conversion with CKSEL HIGH

MC100EP446

The device also features a differential SYNC input (Pins 29 and 30), which asynchronously reset all internal flip-flops and clock circuitry on the rising edge of SYNC. The release of SYNC is a synchronous process, which ensures that no runt serial data bits are generated. The falling edge of the SYNC followed by a falling edge of CLK initiates the start of the conversion process on the next rising edge of CLK (Figures 9 and 10). As shown in the figures below, the device will start to latch the parallel

MC100EP446



MC100EP446

The differential synchronous CKEN inputs (Pins 6 and 7), disable the internal clock circuitry. The synchronous CKEN will suspend all of the device activities and prevent runt pulses from being generated. The rising edge of CKEN followed by the falling edge of CLK will suspend all activities. The falling edge of CKEN followed by the falling edge of CLK will resume all activities (Figure 13).

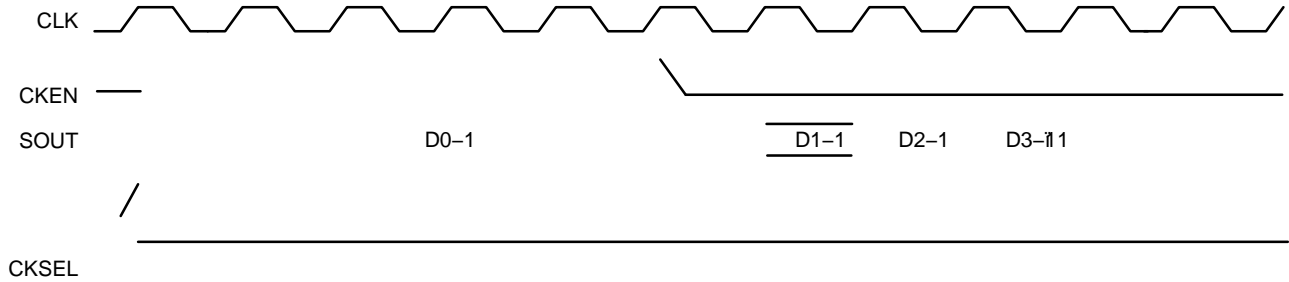

Figure 13. Timing Diagram with CKEN with CKSEL HIGH

MC100EP446

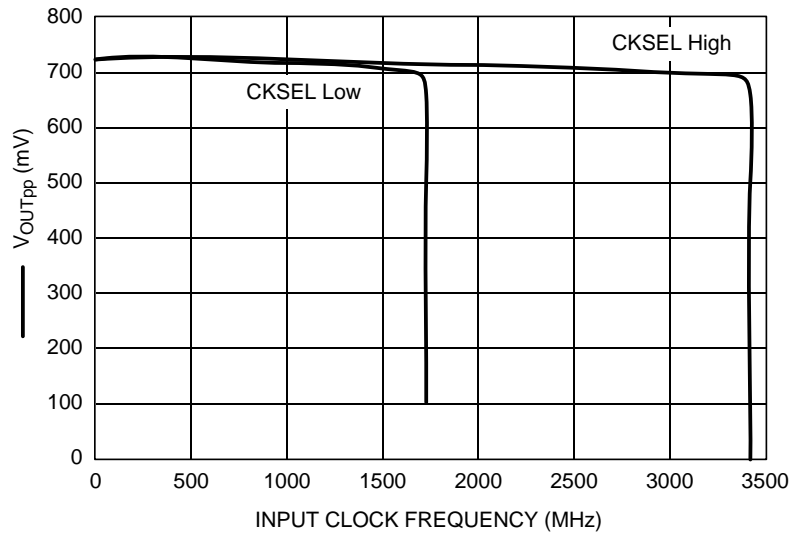

Figure 15. Typical V_{OUTPP} versus Input Clock Frequency, 25°C

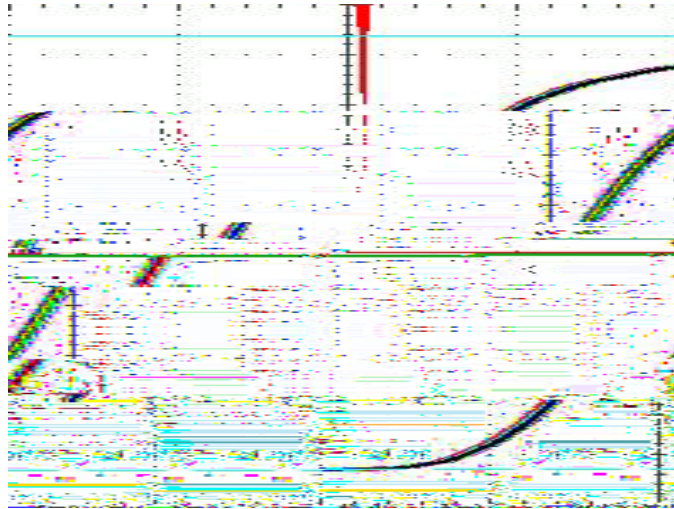

Figure 16. SOUT System Jitter Measurement
(Condition: 3.4 GHz input frequency, CKSEL HIGH, BEOFE32 bit pattern on SOUT)

MC100EP446

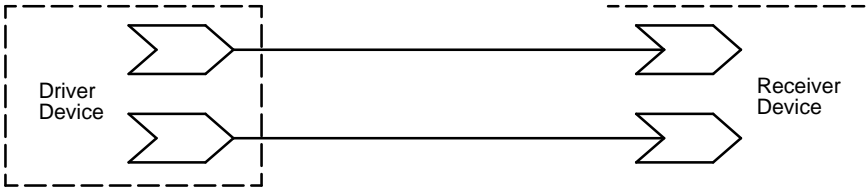
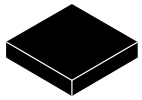

Figure 17. Typical Termination for Output Driver and Device Evaluation
(See Application Note AND8020/D – Termination of ECL Logic Devices.)



QFN32 5x5, 0.5P
CASE 488AM
ISSUE A

DATE 23 OCT 2013

SCALE 2:1

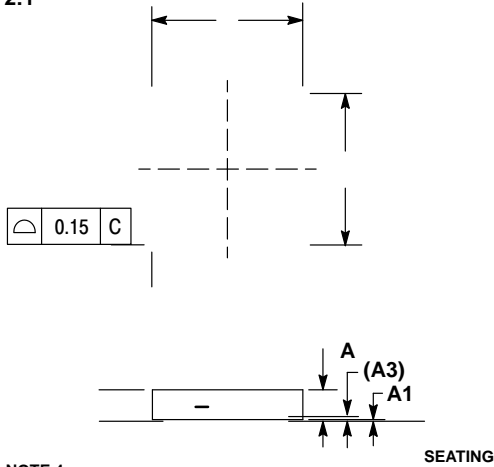

NOTE 4

	MAX
A1	0.80 1.00
A3	0.20 REF 0.05
b	0.18 0.30
D	5.00 BSC
D2	2.95 3.25
E	5.00 BSC
E2	2.95 3.25
e	0.50 BSC
K	0.20
L	0.30 0.50
L1	0.15

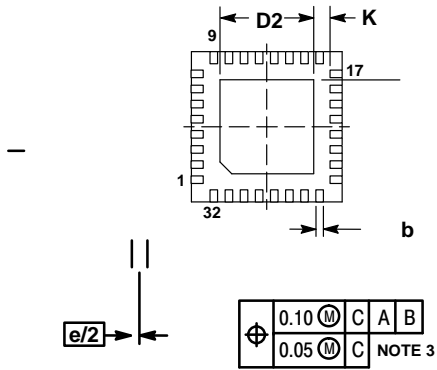

XXXXXXXXXX
XXXXXXXXXX
AWLYYYWW■

■Free indicator, "G" or

RECOMMENDED

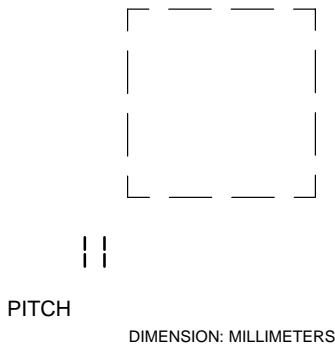

PITCH

DIMENSION: MILLIMETERS

DOCUMENT NUMBER:	98AON20032D	

onsemi, **onsemi**, and other names, marks, and brands are registered and/or common law trademarks of Semiconductor Components Industries, LLC dba "**onsemi**" or its affiliates and/or subsidiaries in the United States and/or other countries. **onsemi** owns the rights to a number of patents, trademarks, copyrights, trade secrets, and other intellectual property. A listing of **onsemi**'s product/patent coverage may be accessed at www.onsemi.com/site/pdf/Patent-Marking.pdf. **onsemi** reserves the right to make changes at any time to any products or information herein, without notice. The information herein is provided "as-is" and **onsemi** makes no warranty, representation or guarantee regarding the accuracy of the information, product features, availability, functionality, or suitability of its products for any particular purpose, nor does **onsemi** assume any liability arising out of the application or use of any product or circuit, and specifically disclaims any and all liability, including without limitation special, consequential or incidental damages. Buyer is responsible for its products and applications using **onsemi**
