

High Temperature, 2.5 A Output Current, Gate Drive Optocoupler

FOD3125

Description

The FOD3125 is a 2.5 A Output Current Gate Drive Optocoupler, capable of driving most medium IGBTs or MOSFETs across extended industrial temperature range, -40°C to 125°C . It is ideally suited for fast switching driving of power IGBTs and MOSFETs used in motor control inverter applications, and high performance power system.

It utilizes ON Semiconductor patented coplanar packaging technology, Optoplanar, and optimized IC design to achieve high noise immunity, characterized by high common mode rejection.

It consists of a gallium aluminum arsenide (AlGaAs) light emitting diode optically coupled to an integrated circuit with a high-speed driver for push-pull MOSFET output stage.

Features

- Extended Industrial Temperature Range, -40°C to 125°C
- High Noise Immunity characterized by 35 kV/ μs minimum Common Mode Rejection
- 2.5 A Peak Output Current Driving Capability for Most 1200 V/ 20 A IGBT
- Use of P-channel MOSFETs at Output Stage Enables Output Voltage Swing close to the Supply Rail
- Wide Supply Voltage Range from 15 V to 30 V
- Fast Switching Speed
 - ◆ 400 ns maximum Propagation Delay
 - ◆ 100 ns maximum Pulse Width Distortion
- Under Voltage LockOut (UVLO) with Hysteresis
- Safety and Regulatory Approvals
 - ◆ UL1577, 5000 V_{RMS} for 1 minute
 - ◆ DIN EN/IEC60747-5-5 (pending approval)
- >8.0 mm Clearance and Creepage Distance (Option 'T' or 'TS')
- 1,414 V Peak Working Insulation Voltage (VIORM)
- This is a Pb-Free Device

Applications

- Industrial Inverter
- Uninterruptible Power Supply
- Induction Heating
- Isolated IGBT/Power MOSFET Gate Drive

Table 1. TRUTH TABLE

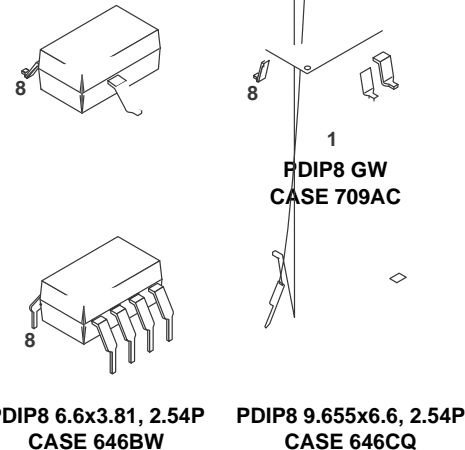

FUNCTIONAL BLOCK DIAGRAM

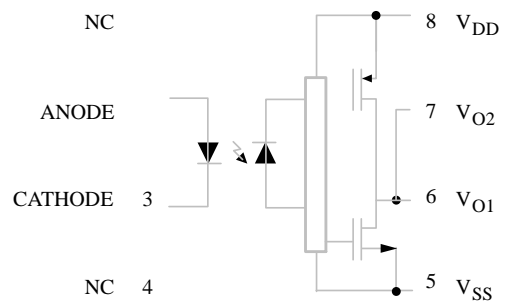

Note: A 0.1 μF bypass capacitor must be connected between pins 5 and 8.

FOD3125

Table 2. PIN DEFINITIONS

Pin #	Name	Description
1	NC	Not Connected
2	Anode	LED Anode
3	Cathode	LED Cathode
4	NC	Not Connected
5	VSS	Negative Supply Voltage
6	VO2	Output Voltage 2 (internally connected to V_{O1})
7	VO1	Output Voltage 1
8	VDD	Positive Supply Voltage

Table 3. SAFETY AND INSULATION RATINGS

A

FOD3125

Table 4. ABSOLUTE MAXIMUM RATINGS ($T_A = 25^\circ\text{C}$ unless otherwise specified.)

Symbol	Parameter	Value	Units
T_{STG}	Storage Temperature	-40 to +125	$^\circ\text{C}$
T_{OPR}	Operating Temperature	-40 to +125	$^\circ\text{C}$
T_J	Junction Temperature	-40 to +125	$^\circ\text{C}$
T_{SOL}	Lead Wave Solder Temperature (refer to page 12 for reflow solder profile)	260 for 10 sec	$^\circ\text{C}$
$I_{F(AVG)}$	Average Input Current	25	mA
f	Operating Frequency ⁽¹⁾	50	kHz
V_R	Reverse Input Voltage	5	V
$I_{O(PEAK)}$	Peak Output Current ⁽²⁾	3	A
$V_{DD} - V_{SS}$	Supply Voltage	0 to 35	V

$T_A \geq 90^\circ\text{C}$

FOD3125

Table 7. ELECTRICAL CHARACTERISTICS (continued)

Symbol	Parameter	Conditions	Min.	Typ.	Max.	Units
C _{IN}	Input Capacitance	f = 1 MHz, V _F = 0 V		20		pF
I _{OH}	High Level Output Current ⁽¹⁾	V _O = V _{DD} - 3 V	-1.0	-2.0		A
		V _O = V _{DD} - 6 V	-2.0			

FOD3125

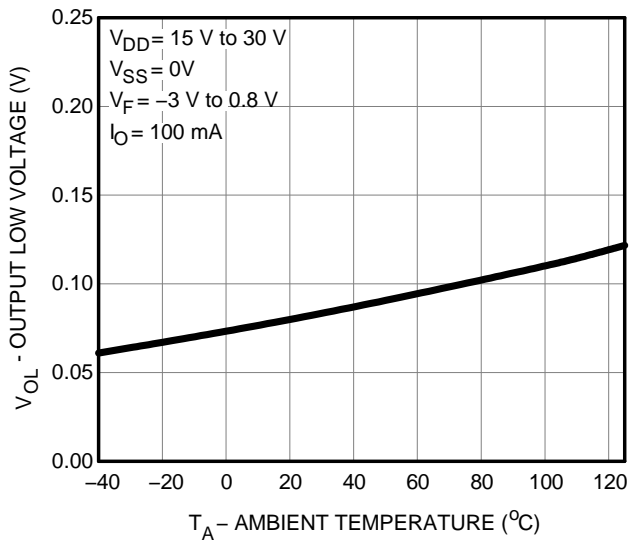

Figure 5. Output Low Voltage vs. Ambient Temperature

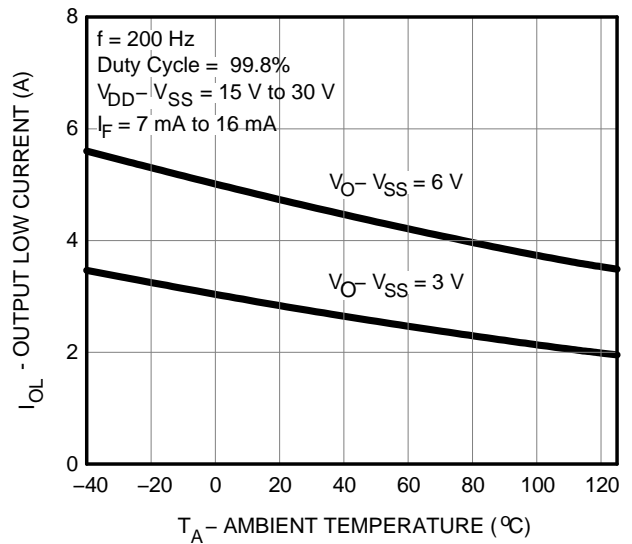

Figure 6. Output Low Current vs. Ambient Temperature

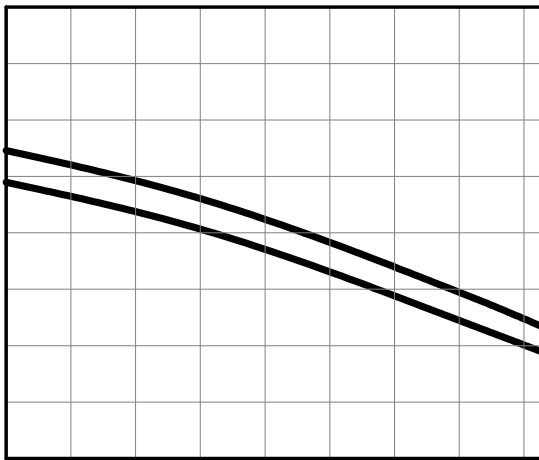
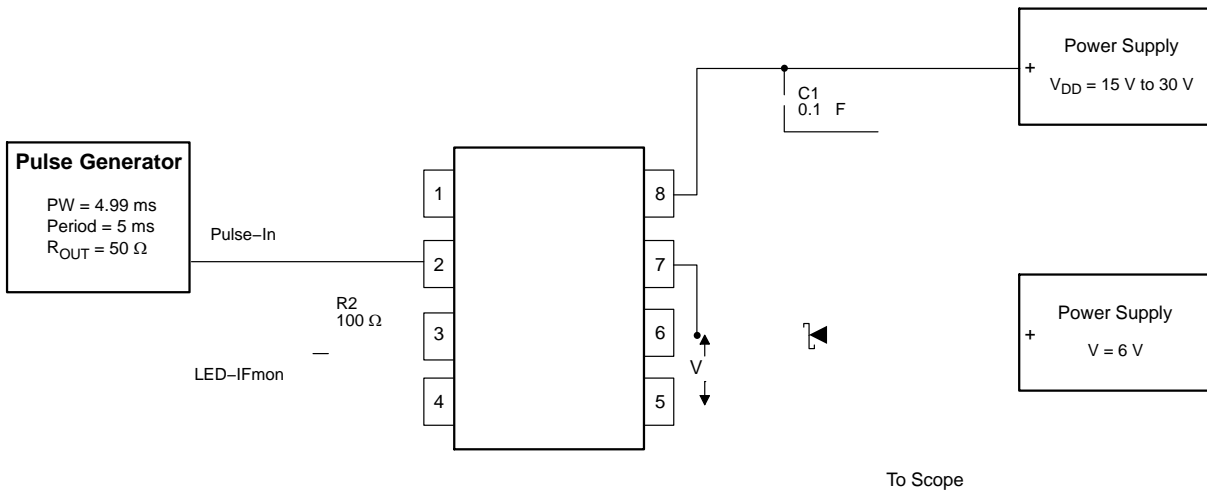

Figure 7. Supply Current vs. Ambient Temperature

FOD3125

FOD3125

TEST CIRCUIT



Test Conditions:

Frequency = 200 Hz
Duty Cycle = 99.8 %
V_{DD}
SS
F_(OFF) = -3.0 V to 0.8 V

Figure 18. I_{OL} Test Circuit

FOD3125

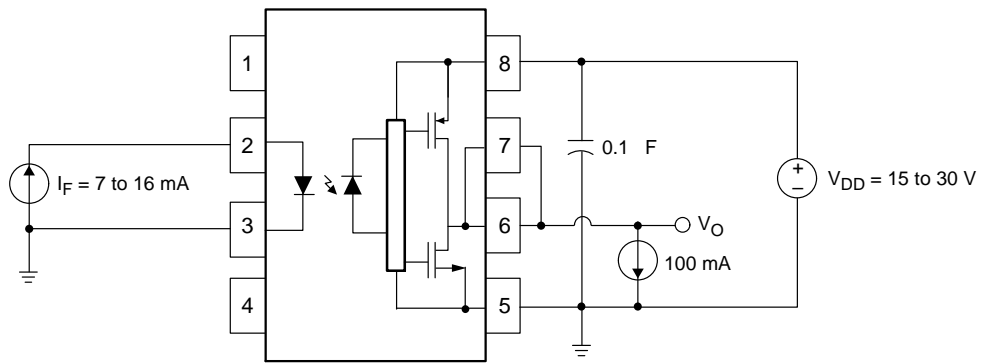

Figure 20. V_{OH} Test Circuit

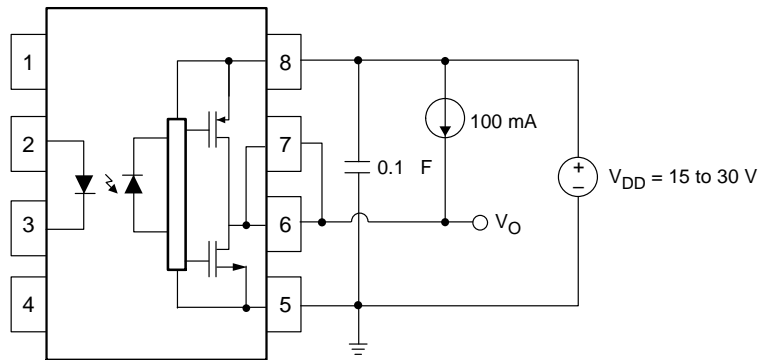

Figure 21. V_{OL} Test Circuit

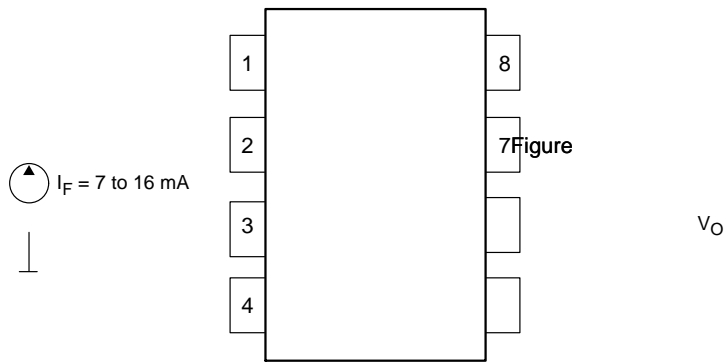

Figure 22. I_{DDH} Test Circuit

FOD3125

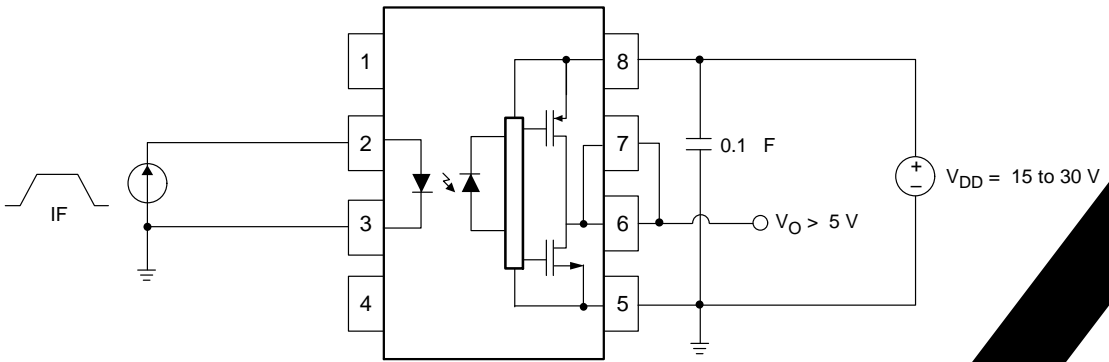

Figure 24. I_{FLH} Test Circuit

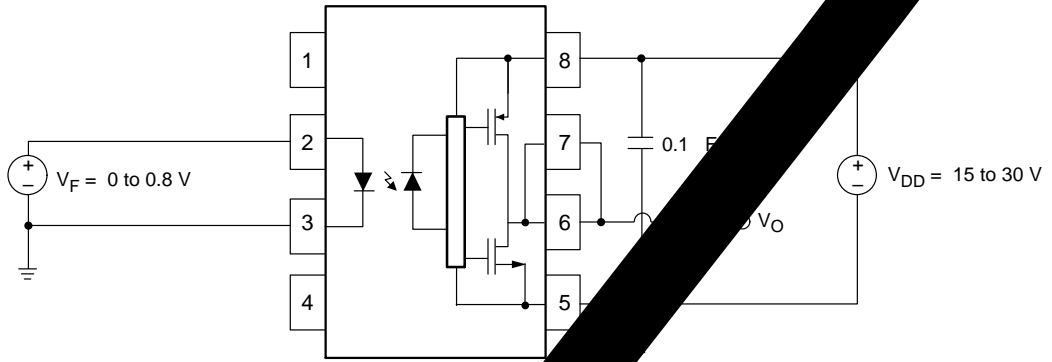

Figure 25. V_F Test Circuit

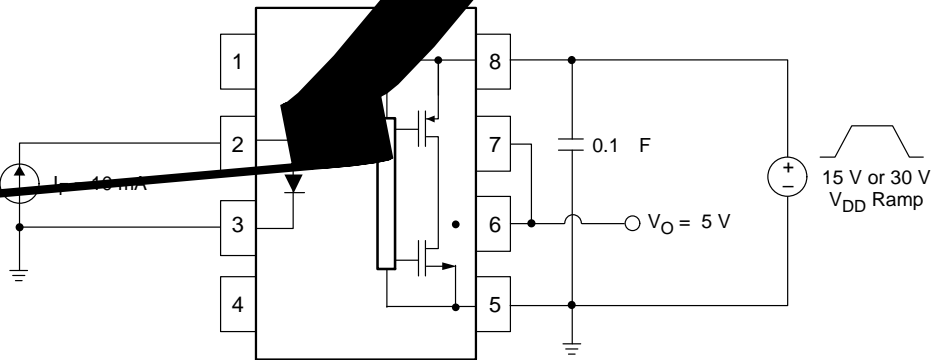

Figure 26. UVLO Test Circuit

FOD3125

FOD3125

REFLOW PROFILE

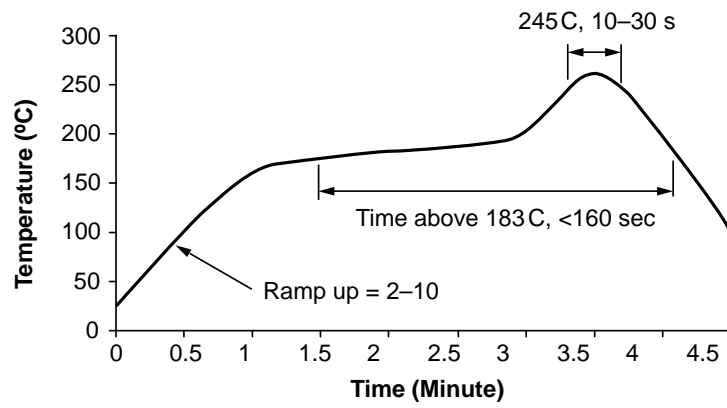

Figure 29. Reflow Profile

FOD3125

CARRIER TAPE SPECIFICATIONS (OPTION SD)

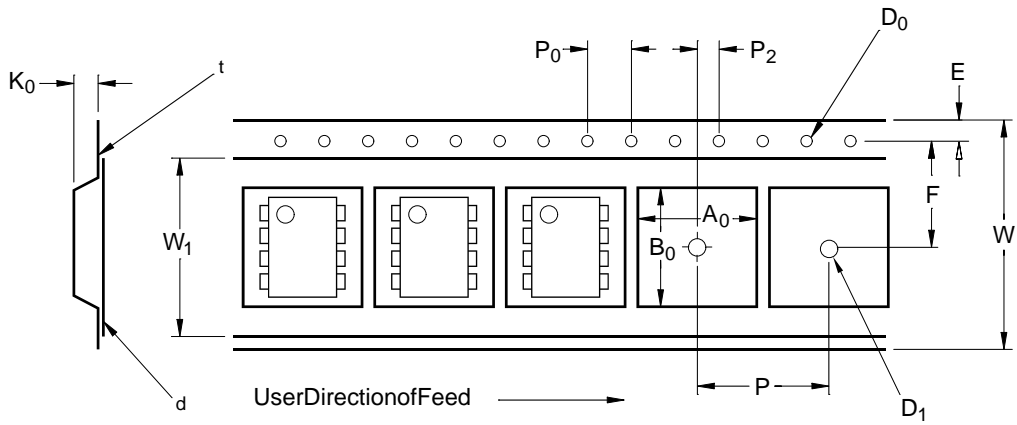

Figure 31. Carrier Tape Specifications

Symbol	Description	Dimension in mm
--------	-------------	-----------------

FOD3125

PACKAGE DIMENSIONS (OPTION TS)

PDIP8 GW
CASE 709AD

FOD3125

PACKAGE DIMENSIONS (OPTION T)

PDIP8 6.6x3.81, 2.54P
CASE 646BW
ISSUE O

NOTES:

- A) NO STANDARD APPLIES TO THIS PACKAGE
- B) ALL DIMENSIC

FOD3125

PACKAGE DIMENSIONS

PDIP8 9.655x6.6, 2.54P
CASE 646CQ
ISSUE O

NOTES:

- A) NO STANDARD APPLIES TO THIS PACKAGE
- B) ALL DIMENSIL