

Optically Isolated Error Amplifier

FOD2711A

Description

The FOD2711A Optically Isolated Amplifier consists of the popular AZ431L precision programmable shunt reference and an optocoupler. The optocoupler is a gallium arsenide (GaAs) light emitting diode optically coupled to a silicon phototransistor. The reference voltage tolerance is 1%. The current transfer ratio (CTR) ranges from 100% to 200%.

It is primarily intended for use as the error amplifier/reference voltage/optocoupler function in isolated AC to DC power supplies and dc/dc converters.

When using the FOD2711A, power supply designers can reduce the component count and save space in tightly packaged designs. The tight tolerance reference eliminates the need for adjustments in many applications.

The device comes in a 8-pin dip white package.

Features

- Optocoupler, Precision Reference and Error Amplifier in Single Package
- 1.240 V ±1% Reference
- CTR 100% to 200%
- 5,000 V RMS Isolation
- UL Approval E90700, Volume 2
- These are Pb-Free Devices

Applications

- Power Supplies Regulation
- DC to DC Converters

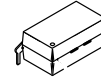

PDIP8 6.6x3.81, 2.54P
CASE 646BW

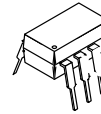

PDIP8 9.655x6.61, 2.54P
CASE 646CQ

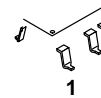

PDIP8 GW
CASE 709AC

MARKING DIAGRAM

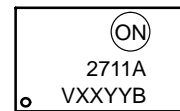

- 2711A = Device Code
- V = VDE Mark (Note: Only Appears on Parts Ordered with VDE Option – See Order Entry Table)
- XX = Two Digit Year Code, e.g., “03”
- YY = Two Digit Work Week Ranging from “01” to “53”
- B = Assembly Package Code

FUNCTIONAL BLOCK DIAGRAM

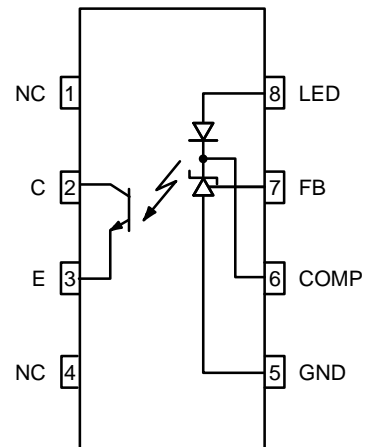

ORDERING INFORMATION

See detailed ordering and shipping information on page 11 of this data sheet.

FOD2711A

PIN DEFINITIONS

Pin No.	Pin Name	Pin Description
1	NC	Not Connected
2	C	Phototransistor Collector
3	E	Phototransistor Emitter
4	NC	Not connected
5	GND	Ground
6	COMP	Error Amplifier Compensation. This pin is the output of the error amplifier.*
7	FB	Voltage Feedback. This pin is the inverting input to the error amplifier
8	LED	Anode LED. This pin is the input to the light emitting diode.

*The compensation network must be attached between pins 6 and 7.

TYPICAL APPLICATION

Figure 1. Typical Application

FOD2711A

ABSOLUTE MAXIMUM RATINGS (T_A = 25°C unless otherwise specified)

Symbol	Parameter	Value	Unit
T _{STG}	Storage Temperature	-40 to +125	°C
T _{OPR}	Operating Temperature	-40 to +85	°C
T _{SOL}	Lead Solder Temperature	260 for 10 sec.	°C
V _{LED}	Input Voltage	13.2	V
I _{LED}	Input DC Current	20	mA
V _{CEO}	Collector-Emitter Voltage	30	V
V _{ECO}	Emitter-Collector Voltage	7	V
I _C	Collector Current	50	mA
PD1	Input Power Dissipation (Note 1)	145	mW
PD2	Transistor Power Dissipation (Note 2)	85	mW
PD3	Total Power Dissipation (Note 3)	145	mW

Stresses exceeding those listed in the Maximum Ratings table may damage the device. If any of these limits are exceeded, device functionality should not be assumed, damage may occur and reliability may be affected.

1. Derate linearly from 25°C at a rate of 2.42 mW/°C.
2. Derate linearly from 25°C at a rate of 1.42 mW/°C.
3. Derate linearly from 25°C at a rate of 2.42 mW/°C.

FOD2711A

ELECTRICAL CHARACTERISTICS ($T_A = 25^\circ\text{C}$ unless otherwise noted)

Symbol	Parameter	Test Conditions	Min	Typ	Max	Unit
INPUT CHARACTERISTICS						
V_F	LED Forward Voltage	$I_{LED} = 10\text{ mA}$, $V_{COMP} = V_{FB}$ (Figure 2)	–	–	1.5	V
V_{REF}	Reference Voltage –40°C to +85°C 25°C	$V_{COMP} = V_{FB}$, $I_{LED} = 10\text{ mA}$ (Figure 2)	1.221	–	1.259	V
			1.228	1.240	1.252	
$V_{REF}(\text{DEV})$	Deviation of V_{REF} Over Temperature (Note 4)	$T_A = -40$ to $+85^\circ\text{C}$	–	4	12	mV
$\frac{\Delta V_{REF}}{\Delta V_{COMP}}$	Ratio of V_{REF} Variation to the Output of the Error Amplifier	$I_{LED} = 10\text{ mA}$, $V_{COMP} = V_{REF}$ to 12 V (Figure 3)	–	–1.5	–2.7	mV/V
I_{REF}	Feedback Input Current	$I_{LED} = 10\text{ mA}$, $R1 = 10\text{ k}\Omega$				

FOD2711A

TYPICAL PERFORMANCE CURVES

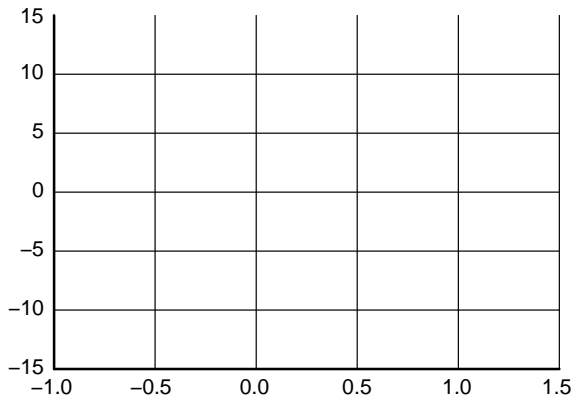

Figure 10.

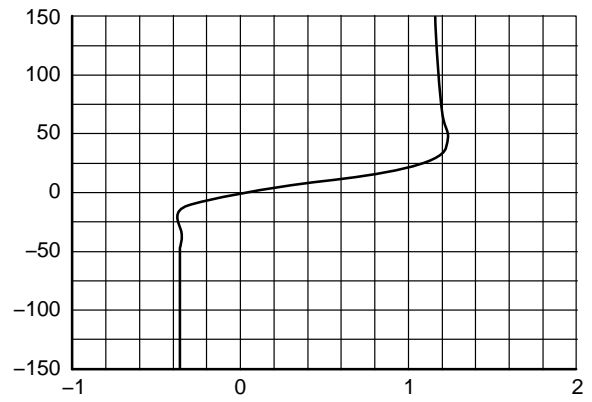

Figure 10b. LED Current vs. Cathode Voltage

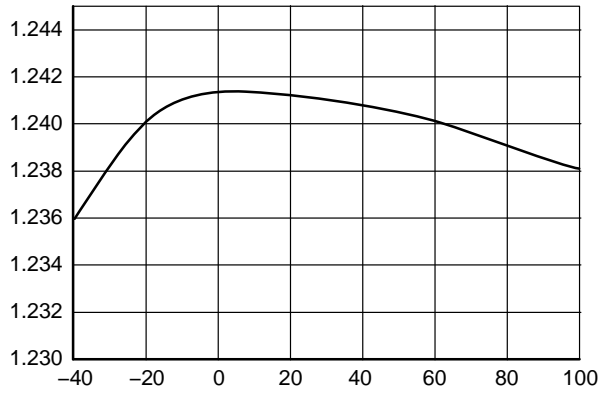

Figure 11. Reference Voltage vs. Ambient Temperature

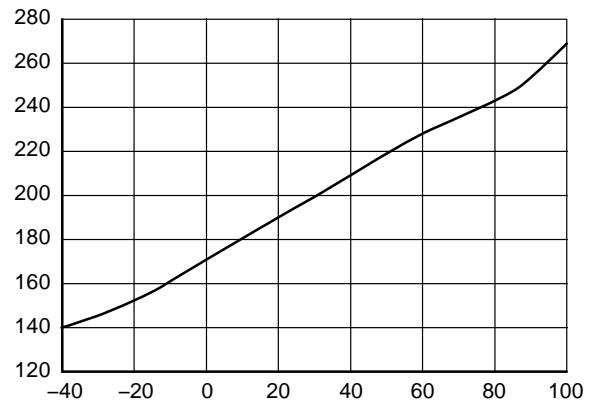
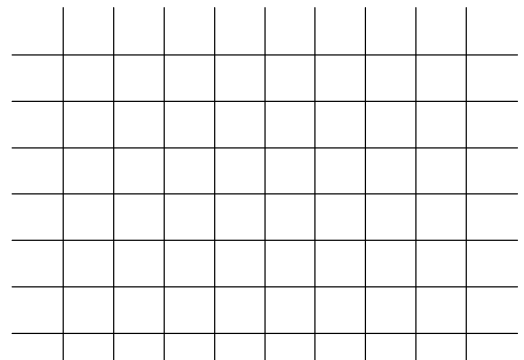
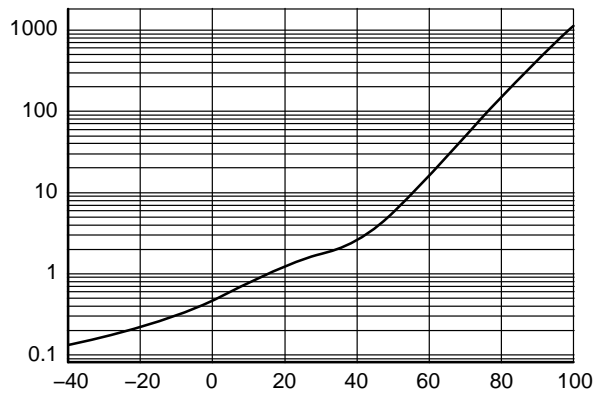

Figure 12. Reference Current vs. Ambient Temperature



TYPICAL PERFORMANCE CURVES (Continued)

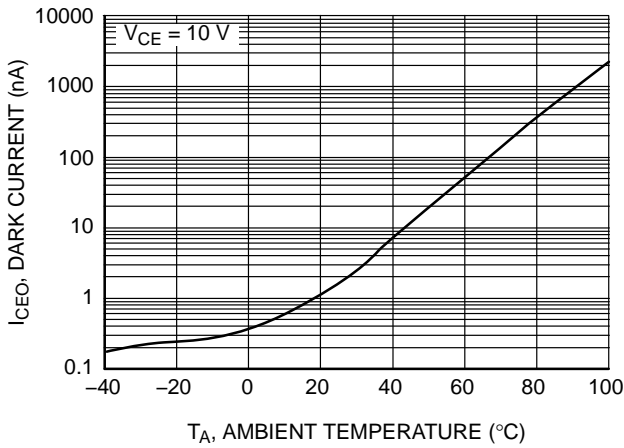

Figure 15. Dark Current vs. Ambient Temperature

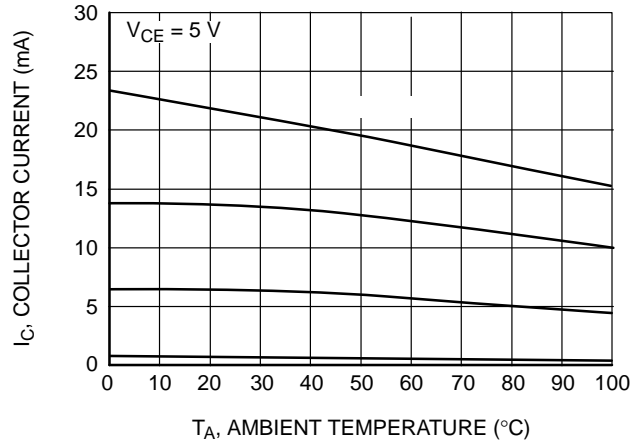

Figure 20. Collector Current vs. Ambient Temperature

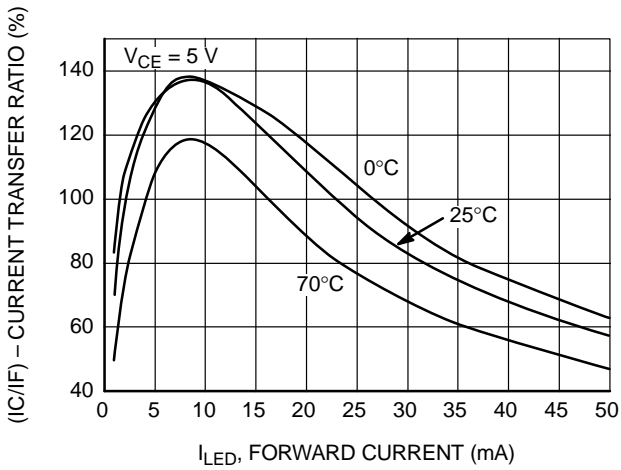

Figure 16. Current Transfer Ratio vs. LED Current

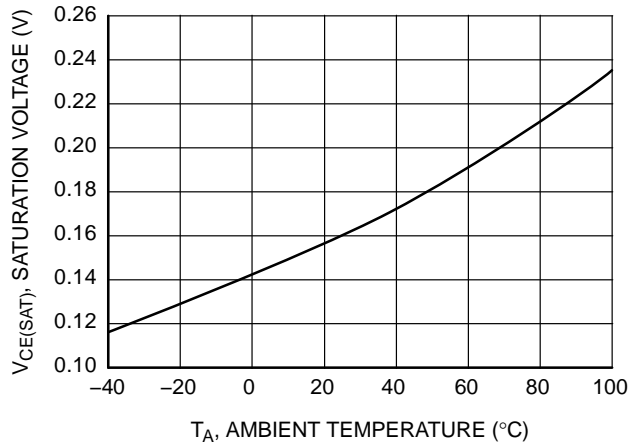

Figure 17. Saturation Voltage vs. Ambient Temperature

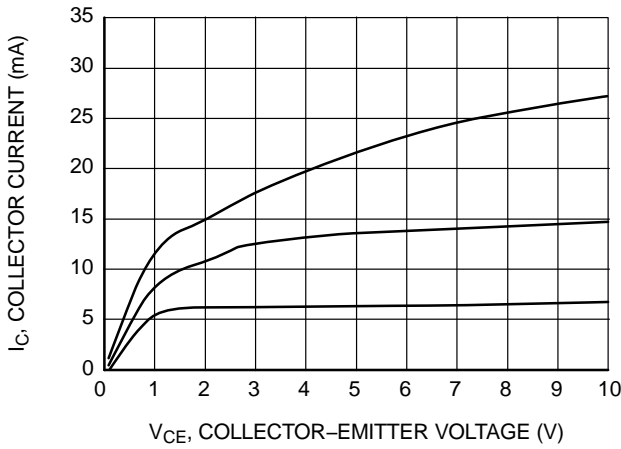

Figure 18. Collector Current vs. Collector Voltage

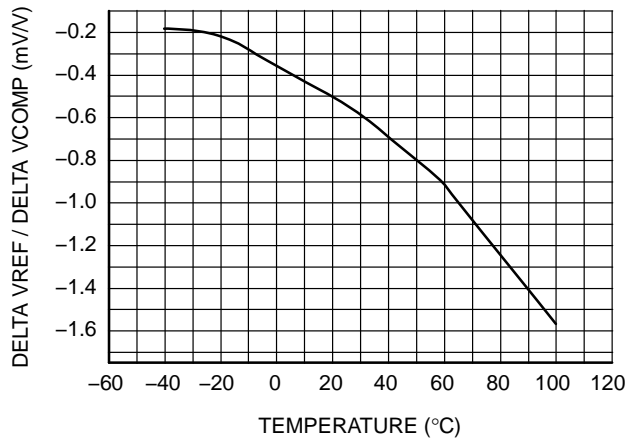

Figure 19. Rate of Change Vref to Vcomp vs. Temperature

FOD2711A

TYPICAL PERFORMANCE CURVES (Continued)

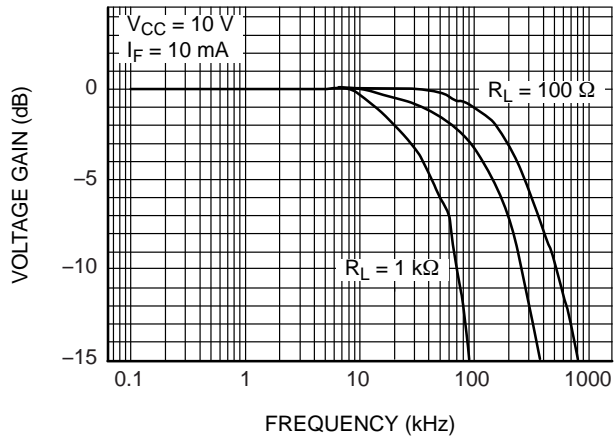

Figure 21. Voltage Gain vs. Frequency

FOD2711A

THE FOD2711A

The FOD2711A is an optically isolated error amplifier. It incorporates three of the most common elements necessary to make an isolated power supply, a reference voltage, an error amplifier, and an optocoupler. It is functionally equivalent to the popular AZ431L shunt voltage regulator plus the CNY17F-3 optocoupler.

Powering the Secondary Side

The LED pin in the FOD2711A powers the secondary side, and in particular provides the current to run the LED. The actual structure of the FOD2711A dictates the minimum voltage that can be applied to the LED pin: The error amplifier output has a minimum of the reference voltage, and the LED is in series with that. Minimum voltage applied to the LED pin is thus $1.24\text{ V} + 1.5\text{ V} = 2.74\text{ V}$. This voltage can be generated either directly from the output of the converter, or else from a slaved secondary winding. The secondary winding will not affect regulation, as the input to the FB pin may still be taken from the output winding.

The LED pin needs to be fed through a current limiting resistor. The value of the resistor sets the amount of current through the LED, and thus must be carefully selected in conjunction with the selection of the primary side resistor.

Feedback

Output voltage of a converter is determined by selecting a resistor divider from the regulated output to the FB pin. The FOD2711A attempts to regulate its FB pin to the reference voltage, 1.24 V. The ratio of the two resistors should thus be:

$$\frac{R_{\text{TOP}}}{R_{\text{BOTTOM}}} = \frac{V_{\text{OUT}}}{V_{\text{REF}}} - 1 \quad (\text{eq. 3})$$

The absolute value of the top resistor is set by the input offset current of $0.8\text{ }\mu\text{A}$. To achieve 1% accuracy, the resistance of R_{TOP} should be:

$$\frac{V_{\text{OUT}} - 1.24}{R_{\text{TOP}}} > 80\text{ }\mu\text{A} \quad (\text{eq. 4})$$

Compensation

The compensation pin of the FOD2711A provides the opportunity for the designer to design the frequency response of the converter. A compensation network may be

placed between the COMP pin and the FB pin. In typical low-bandwidth systems, a $0.1\text{ }\mu\text{F}$ capacitor may be used. For converters with more stringent requirements, a network should be designed based on measurements of the system's loop. An excellent reference for this process may be found in "Practical Design of Power Supplies" by Ron Lenk, IEEE Press, 1998.

Secondary Ground

The GND pin should be connected to the secondary ground of the converter.

No Connect Pins

The NC pins have no internal connection. They should not have any connection to the secondary side, as this may compromise the isolation structure.

Photo-Transistor

The Photo-transistor is the output of the FOD2711A. In a normal configuration the collector will be attached to a pull-up resistor and the emitter grounded. There is no base connection necessary.

The value of the pull-up resistor, and the current limiting resistor feeding the LED, must be carefully selected to account for voltage range accepted by the PWM IC, and for the variation in current transfer ratio (CTR) of the opto-isolator itself.

Example: The voltage feeding the LED pins is +12 V, the voltage feeding the collector pull-up is +10 V, and the PWM IC is the **onsemi** KA1H0680, which has a 5 V reference. If we select a $10\text{ k}\Omega$ resistor for the LED, the maximum current through the collector will be 27 nA with a 0.4 mA typical current.

FOD2711A

REFLOW PROFILE

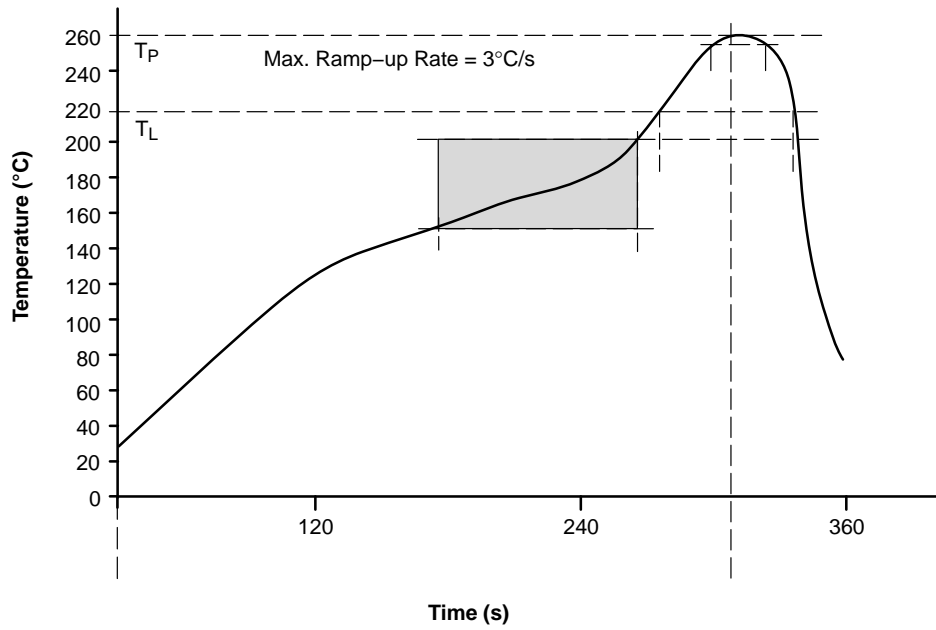

Figure 22. Reflow Profile

PDIP8 9.655x6.6, 2.54P
CASE 646CQ
ISSUE O

DATE 18 SEP 2017

CE

ON.

AND TIE BAR EXTRUSI

PDIP8 GW
CASE 709AC
ISSUE O

DATE 31 JUL 2016

35-6.86

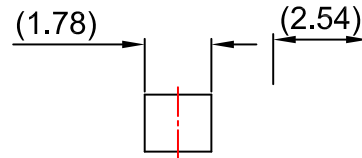

LAND S

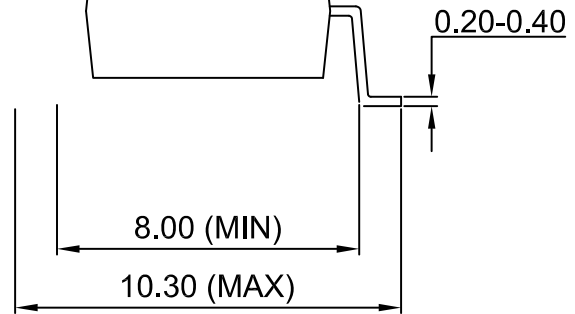
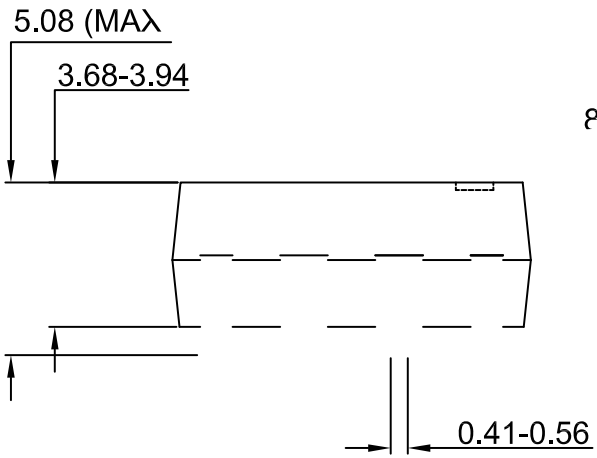

TO THIS PACKAGE

B) ALL DIMENSIONS ARE IN MILLIMETERS.

C) DIMEN*

BAR EXTRUSI

onsemi, **onsemi**, and other names, marks, and brands are registered and/or common law trademarks of Semiconductor Components Industries, LLC dba "**onsemi**" or its affiliates and/or subsidiaries in the United States and/or other countries. **onsemi** owns the rights to a number of patents, trademarks, copyrights, trade secrets, and other intellectual property. A listing of **onsemi**'s product/patent coverage may be accessed at www.onsemi.com/site/pdf/Patent-Marking.pdf. **onsemi** reserves the right to make changes at any time to any products or information herein, without notice. The information herein is provided "as-is" and **onsemi** makes no warranty, representation or guarantee regarding the accuracy of the information, product features, availability, functionality, or suitability of its products for any particular purpose, nor does **onsemi** assume any liability arising out of the application or use of any product or circuit, and specifically disclaims any and all liability, including without limitation special, consequential or incidental damages. Buyer is responsible for its products and applications using **onsemi**
