

# CS8312

## IGBT Ignition Predriver with Dynamic Current Regulation

The CS8312 is a bipolar microprocessor interface IC designed to drive an IGBT (or logic level MOSFETs) powering large inductive loads in harsh operating environments. The IC's dynamic current limit function lets the microprocessor adjust the current limit threshold to the real time needs of the system.

CLI, the current limit input, sets the current limit for the IGBT high or low as directed by the system microprocessor. CLI also raises and lowers the threshold on the diagnostic FLAG output signal. The FLAG output signals the microprocessor when the current level approaches current limit on the IGBT. The CTRL input enables the FLAG function.

### Features

- $\mu$ P Compatible Inputs
- Adjustable Current Limit Thresholds
- External Sense Resistor
- Flag Signal to Indicate Output Status

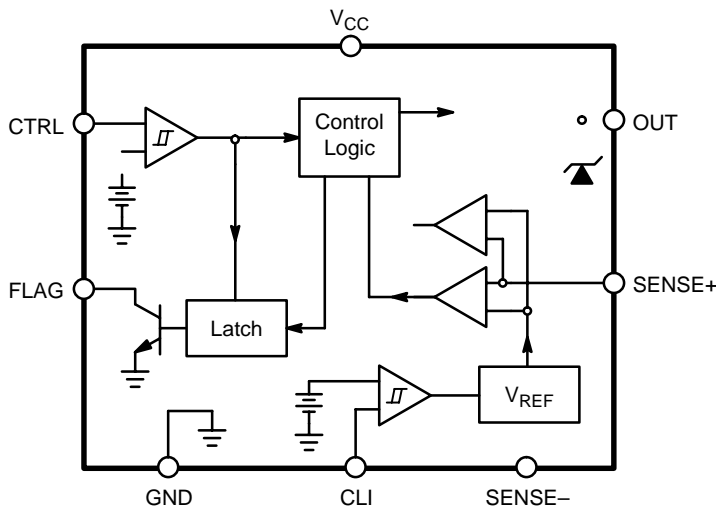
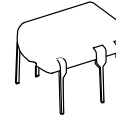

Figure 1. Block Diagram



ON Semiconductor™



# CS8312

## ABSOLUTE MAXIMUM RATINGS\*

Rating	Value	Unit
Supply Voltage	-0.3 to 12	V
Digital Input Currents	2.0	mA
Internal Power Dissipation ( $T_A = 25^\circ\text{C}$ )	700	mW
Junction Temperature Range	-40 to +150	$^\circ\text{C}$
Storage Temperature Range	-55 to +165	$^\circ\text{C}$
Electrostatic Discharge (Human Body Model)	2.0	kV
Lead Temperature Soldering	Wave Solder (through hole styles only) Note 1. Reflow (SMD styles only) Note 2.	260 peak 230 peak $^\circ\text{C}$

1. 10 seconds max.

2. 60 seconds max above  $183^\circ\text{C}$

\*The maximum package power dissipation must be observed.

## ELECTRICAL CHARACTERISTICS ( $7.0\text{ V} \leq V_{\text{CC}} \leq 10\text{ V}$ , $-40^\circ\text{C} \leq T_A \leq 125^\circ\text{C}$ , $-0.2\text{ V} \leq$ Differential Ground Voltage $\leq 0.8\text{ V}$ ; unless otherwise specified.)

Characteristic	Test Conditions	Min	Typ	Max	Unit
<b>General</b>					
Power Supply Including Ripple Voltage	-	7.0	-	10	V
Supply Ripple Frequency	-	10	-	60	kHz
Differential Ground Frequency	-	10	-	60	kHz

Quiescent Current,  $I_Q$

Turn On

Turn Off

# CS8312

**ELECTRICAL CHARACTERISTICS (continued)** ( $7.0\text{ V} \leq V_{CC} \leq 10\text{ V}$ ,  $-40^\circ\text{C} \leq T_A \leq 125^\circ\text{C}$ ,  $-0.2\text{ V} \leq \text{Differential Ground Voltage} \leq 0.8\text{ V}$ ; unless otherwise specified.)

Characteristic	Test Conditions	Min	Typ	Max	Unit
----------------	-----------------	-----	-----	-----	------

## Current Limit Increase Function (continued)

Input Capacitance	–	–	–	50	pF
-------------------	---	---	---	----	----

## Output Stage

$I_{OUT}$	–	–	–	5.0	mA
Clamp Voltage	$V_{CTRL} = 5.5\text{ V}$ , $I_{OUT} = 1.0\text{ mA}$	4.0	–	5.5	V
Output Off Voltage	$V_{CTRL} = -0.3\text{ V}$ , $I_{OUT} = 10\text{ }\mu\text{A}$ $V_{CTRL} = -0.3\text{ V}$ , $I_{OUT} = 200\text{ }\mu\text{A}$	–	–	0.5 1.2	V V

## Flag Function

Output Low	$V_{CTRL} = 5.5\text{ V}$ , $I_{FLAG} = 1.5\text{ mA}$	–	–	0.9	V
Leakage Current	$V_{CTRL} = -0.3\text{ V}$	–	–	10	$\mu\text{A}$
Output Capacitance	–	–	–	50	pF
Turn On ( $V_{SENSE+} - V_{SENSE-}$ )	$V_{CTRL} = 5.5\text{ V}$ , $V_{CLI} = -0.3\text{ V}$ $V_{CTRL} = 5.5\text{ V}$ , $V_{CLI} = 5.5\text{ V}$	210 300	225 –	240 350	mV mV
Turn Off Delay	CTRL Decreasing	–	–	10	$\mu\text{s}$
Turn On Delay	–	–	–	10	$\mu\text{s}$
Disable Time	–	100	–	450	$\mu\text{s}$

## Sense Function

Input Voltage Range	–	-0.3	–	2.5	V
Sense Regulation Voltage	$V_{CTRL} = 5.5\text{ V}$ , $V_{CLI} = -0.3\text{ V}$ $V_{CTRL} = 5.5\text{ V}$ , $V_{CLI} = 5.5\text{ V}$	270 380	295 410	320 440	mV mV
Input Leakage Current	$V_{CTRL} = 5.5\text{ V}$	–	–	5.0	$\mu\text{A}$
Propagation Delay	$V_{CTRL} = 5.5\text{ V}$	–	–	20	$\mu\text{s}$

## PACKAGE PIN DESCRIPTION

PACKAGE PIN #		PIN SYMBOL	FUNCTION
DIP-8	SO-8		
1	1	FLAG	Indicates whether current through the IGBT has reached a pre-set level.
2	2	SENSE+	Positive input to current comparator.
3	3	SENSE-	Ground (SENSE-) for current sense resistor.
4	4	GND	Ground connection.
5	5	OUT	Output voltage to IGBT (MOSFET) gate.
6	6	CLI	Current limit input increase.
7	7	CTRL	Control input.
8	8	$V_{CC}$	Supply voltage.

CIRCUIT DESCRIPTION

**Flag Function (See Figure 2)**

The flag indicates when the voltage across the two sense pins is approaching a current limit level that has been determined by the value of the external sense resistor ( $R_{SENSE}$ ) and the state of the CTRL and CLI pins. If the voltage across the sense pins (SENSE+, SENSE-) is less than the flag turn-on voltage, then the FLAG is off. When the voltage between the sense pins equals the FLAG turn on voltage, the FLAG will latch on until the CTRL pin goes low. FLAG is disabled whenever CTRL is low. Changing the CLI pin from low to high will increase nominal FLAG turn on voltage by approximately 45%.

**Table 1. FLAG Timing Sequence**

State	CONTROL	SENSE+	FLAG
0	Low	X	OFF
1	High	Below Threshold	OFF
2	High	Above Threshold	ON
3	High	X	ON
0	Low	X	OFF

**Output Stage**

The CS8312 output (OUT) saturates and supplies voltage to the IGBT (or MOSFET) gate once the CTRL switches from low to high. As current through the IGBT (MOSFET) increases and the voltage across the sense resistor passes the flag turn on voltage, the FLAG will turn on. If the current through the sense resistor continues to rise and the sense resistor voltage reaches the regulation sense voltage, then the gate voltage will fall to a level that regulates the driver and maintains the regulation sense voltage at the sense resistor.

**Current Limit Function**

Changing the CLI pin from a logic low to a logic high

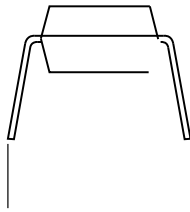
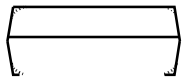

-X-

- - - -

⊕ 0. (0.010) ○ ○

-Y-

- - - -

G

-Z-

C	1.35	1.75	0.053	0.069
D	0.33	0.51	0.013	0.020
G	1.27 BSC		0.050 BSC	
H	0.10	0.25	0.004	0.010
J	0.19	0.25	0.007	0.010
K	0.40	1.27	0.016	0.050
M	0	8	0	8
N	0.25	0.50	0.010	0.020
S	5.80	6.20	0.228	0.244

0. (0.010) ○ 101100 1.000 0.1 1011. 100 0001.1 1001 1 0( )01.1 100111.1 10000 5.80 6.20 0.228 0.244 1.0 0 1000 0. )

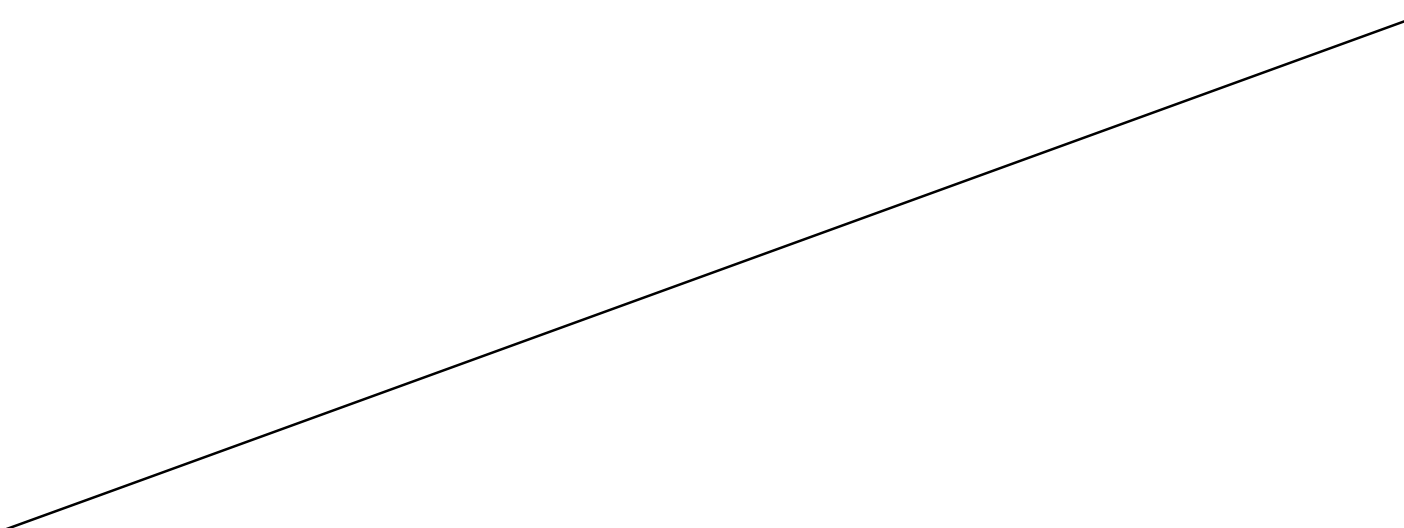



**onsemi**, **onsemi**, and other names, marks, and brands are registered and/or common law trademarks of Semiconductor Components Industries, LLC dba "**onsemi**" or its affiliates and/or subsidiaries in the United States and/or other countries. **onsemi** owns the rights to a number of patents, trademarks, copyrights, trade secrets, and other intellectual property. A listing of **onsemi**'s product/patent coverage may be accessed at [www.onsemi.com/site/pdf/Patent-Marking.pdf](http://www.onsemi.com/site/pdf/Patent-Marking.pdf). **onsemi** reserves the right to make changes at any time to any products or information herein, without notice. The information herein is provided "as-is" and **onsemi** makes no warranty, representation or guarantee regarding the accuracy of the information, product features, availability, functionality, or suitability of its products for any particular purpose, nor does **onsemi** assume any liability arising out of the application or use of any product or circuit, and specifically disclaims any and all liability, including without limitation special, consequential or incidental damages. Buyer is responsible for its products and applications using **onsemi**

---

---