

AMIS-30663

High Speed CAN Transceiver

Introduction

The AMIS 30663 CAN transceiver is the interface between a controller area network (CAN) protocol controller and the physical bus and may be used in both 12 V and 24 V systems. The digital interface level is powered from a 3.3 V supply providing true I/O voltage levels for 3.3 V CAN controllers.

The transceiver provides differential transmit capability to the bus and differential receive capability to the CAN controller. Due to the wide common mode voltage range of the receiver inputs, the AMIS 30663 is able to reach outstanding levels of electromagnetic susceptibility (EMS). Similarly, extremely low electromagnetic emission (EME) is achieved by the excellent matching of the output signals.

Key Features

- Fully Compatible with the “ISO 11898 2” Standard
- out Function

- Thermal Protection
- Bus Pins Protected Against Transients in an Automotive



<http://onsemi.com>

PIN ASSIGNMENT

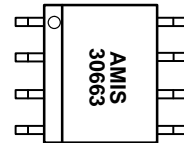

		Package	Container		Temp. Range
			Shipping Configuration	Quantity	
					° °
					° °

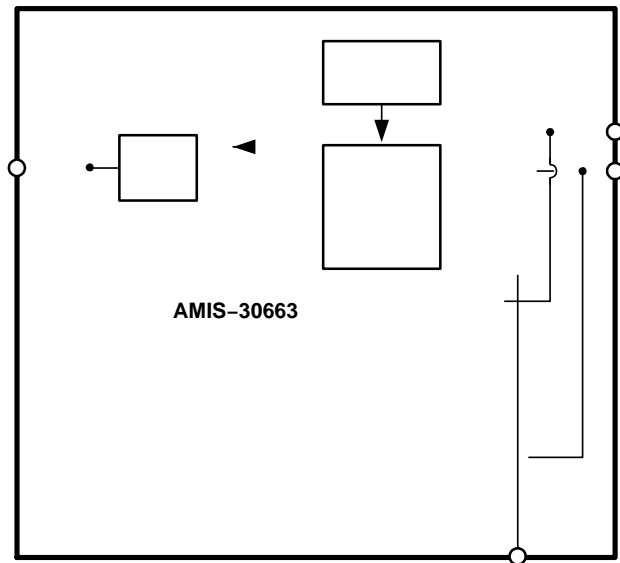

Figure 1. Block Diagram

AMIS-30663

Typical Application

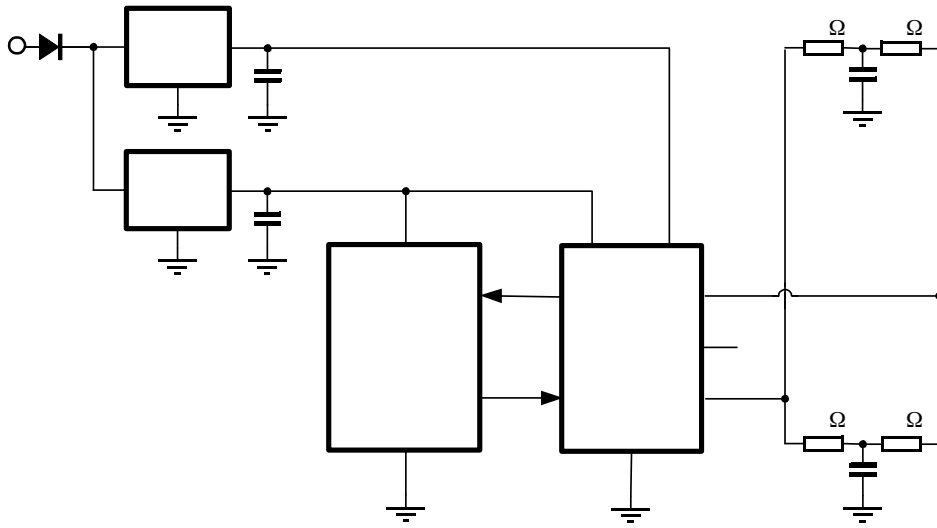

Figure 2. Application Diagram

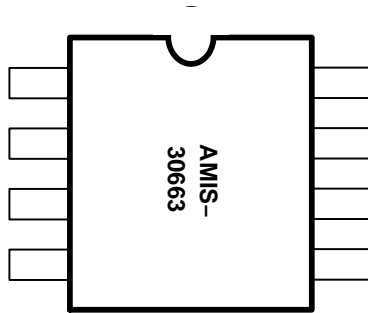

Figure 3. Pin Configuration

Table 3. Pin Out

Pin	Name	Description
		→
		→

Functional Description

General

The AMIS 30663 is the interface between the CAN protocol controller and the physical bus. It is intended for use in automotive and industrial applications requiring baud rates up to 1 Mbaud. It provides differential transmit capability to the bus and differential receiver capability to the CAN protocol controller. It is fully compatible to the “ISO 11898 2” standard.

Operating Modes

AMIS 30663 only operates in high speed mode as illustrated in Table 4.

The transceiver is able to communicate via the bus lines. The signals are transmitted and received to the CAN controller via the pins TxD and RxD. The slopes on the bus lines outputs are optimised to give extremely low EME.

Table 4. Function Table (X = don't care)

Mode	Pin		Bus		
	TxD	RxD	State	CANH	CANL
4. 5	5.25				
	4. 5				

Over-temperature Detection

A thermal protection circuit protects the IC from damage by switching off the transmitter if the junction temperature exceeds a value of approximately 160°C. Because the transmitter dissipates most of the power, the power dissipation and temperature of the IC is reduced. All other IC functions continue to operate. The transmitter off state resets when pin TxD goes HIGH. The thermal protection circuit is particularly needed when a bus line short circuits.

TxD Dominant Time-

AMIS-30663

Table 5. Absolute Maximum Ratings

Symbol	Parameter	Conditions	Min.	Max.	Unit

Table 7. DC Characteristics

Symbol	Parameter	Conditions	Min.	Typ.	Max.	Unit
Bus Lines (pins CANH and CANL)						
						Ω
						μ
						μ
	→ →					
Power on Reset						
Thermal Shutdown						
						°
Timing Characteristics						

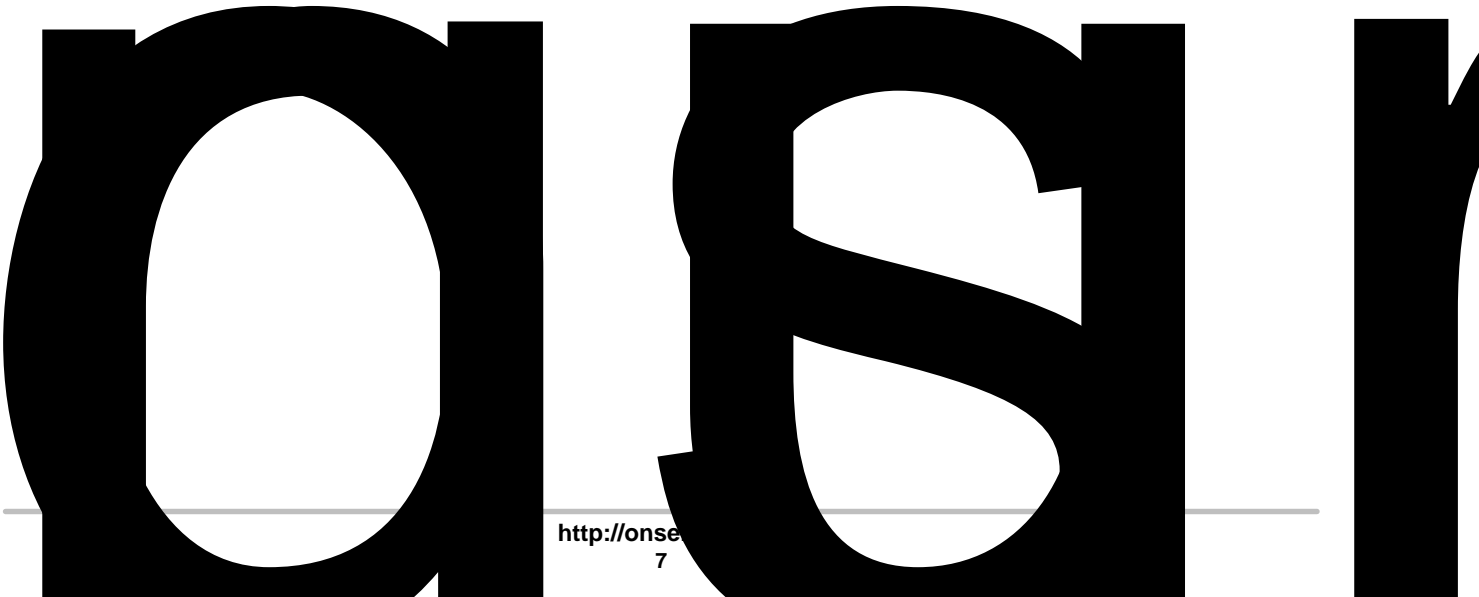

AMIS-30663

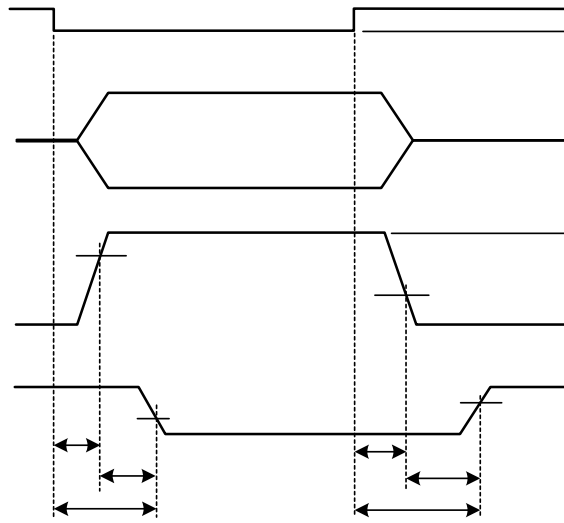
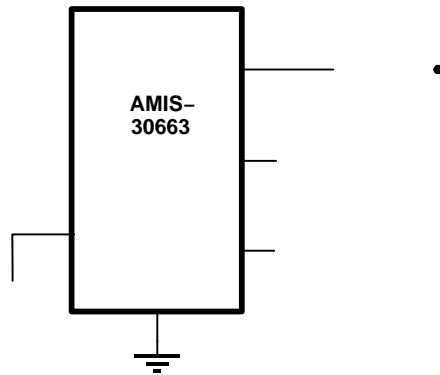

Figure 7. Timing Diagram for AC Characteristics



Soldering

Introduction to Soldering Surface Mount Packages

This text gives a very brief insight to a complex technology. A more in depth account of soldering ICs can be found in the ON Semiconductor "Data Handbook IC26; Integrated

SOIC-8
CASE 751AZ
ISSUE B

DATE 18 MAY 2015

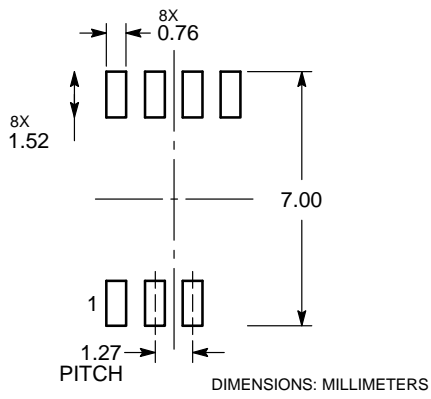

*For

onsemi, **onsemi**, and other names, marks, and brands are registered and/or common law trademarks of Semiconductor Components Industries, LLC dba "**onsemi**" or its affiliates and/or subsidiaries in the United States and/or other countries. **onsemi** owns the rights to a number of patents, trademarks, copyrights, trade secrets, and other intellectual property. A listing of **onsemi**'s product/patent coverage may be accessed at www.onsemi.com/site/pdf/Patent-Marking.pdf. **onsemi** reserves the right to make changes at any time to any products or information herein, without notice. The information herein is provided "as-is" and **onsemi** makes no warranty, representation or guarantee regarding the accuracy of the information, product features, availability, functionality, or suitability of its products for any particular purpose, nor does **onsemi** assume any liability arising out of the application or use of any product or circuit, and specifically disclaims any and all liability, including without limitation special, consequential or incidental damages. Buyer is responsible for its products and applications using **onsemi**
