

2-Input Multiplexer

74 HC157

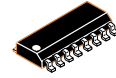

The VHC157 is an advanced high speed CMOS Quad 2–Channel Multiplexer fabricated with silicon gate CMOS technology. It achieves the high speed operation similar to equivalent Bipolar Schottky TTL while maintaining the CMOS low power dissipation.

It consists of four 2–input digital multiplexers with common select and enable inputs. When the $\overline{\text{ENABLE}}$ input is held “H” level, selection of data is inhibited and all the outputs become “L” level. The SELECT decoding determines whether the I 0x or I 1x inputs get routed to their corresponding outputs.

An Input protection circuit ensures that 0 V to 5.5 V can be applied to the input pins without regard to the supply voltage. This device can be used to interface 5 V to 3 V systems and on two supply systems such as battery back up. This circuit prevents device destruction due to mismatched supply and input voltages.

- High Speed: $t_{PD} = 4.1 \text{ ns}$ (Typ.) at $V_{CC} = 5 \text{ V}$
- Source Power Dissipation: $I_{CC} = 4 \mu\text{A}$ (Max.) at $T_A = 25^\circ\text{C}$
- Enable Input Immunity: $V_{NIH} = V_{NIL} = 28\% V_{CC}$ (Min.)

See detailed ordering and shipping information in the package dimensions section on page 6 of this data sheet.

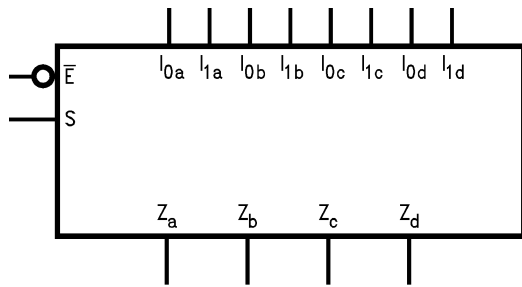

The VHC157 is a quad 2-input multiplexer. It selects four bits of data from two sources under the control of a common Select input (S). The Enable input (\bar{E}) is active-LOW. When \bar{E} is HIGH, all of the outputs (Z) are forced LOW regardless of all other inputs. The VHC157 is the logic implementation of a 4-pole, 2-position switch where the position of the switch is determined by the logic levels supplied to the Select input. The logic equations for the outputs are shown below:

$$Z_a = \bar{E} \cdot (I_{1a} \cdot S + I_{0a} \cdot \bar{S})$$

$$Z_b = \bar{E} \cdot (I_{1b} \cdot S + I_{0b} \cdot \bar{S})$$

$$Z_c = \bar{E} \cdot (I_{1c} \cdot S + I_{0c} \cdot \bar{S})$$

$$Z_d = \bar{E} \cdot (I_{1d} \cdot S + I_{0d} \cdot \bar{S})$$

A common use of the VHC157 is the moving of data from two groups of registers to four common output busses. The particular register from which the data comes is determined by the state of the Select input. A less obvious use is as a function generator. The VHC157 can generate any four of the sixteen different functions of two variables with one variable common. This is useful for implementing gating functions.

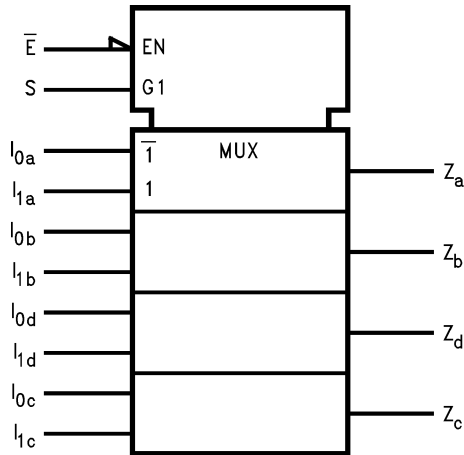

\bar{E}	S	I_{0a}	I_{1a}	Output
H	X	X	X	L
L	H	X	L	L
L	H	X	H	H
L	L	L	X	L
L	L	H	X	H

H = HIGH Voltage Level

L = LOW Voltage Level

X = Immaterial

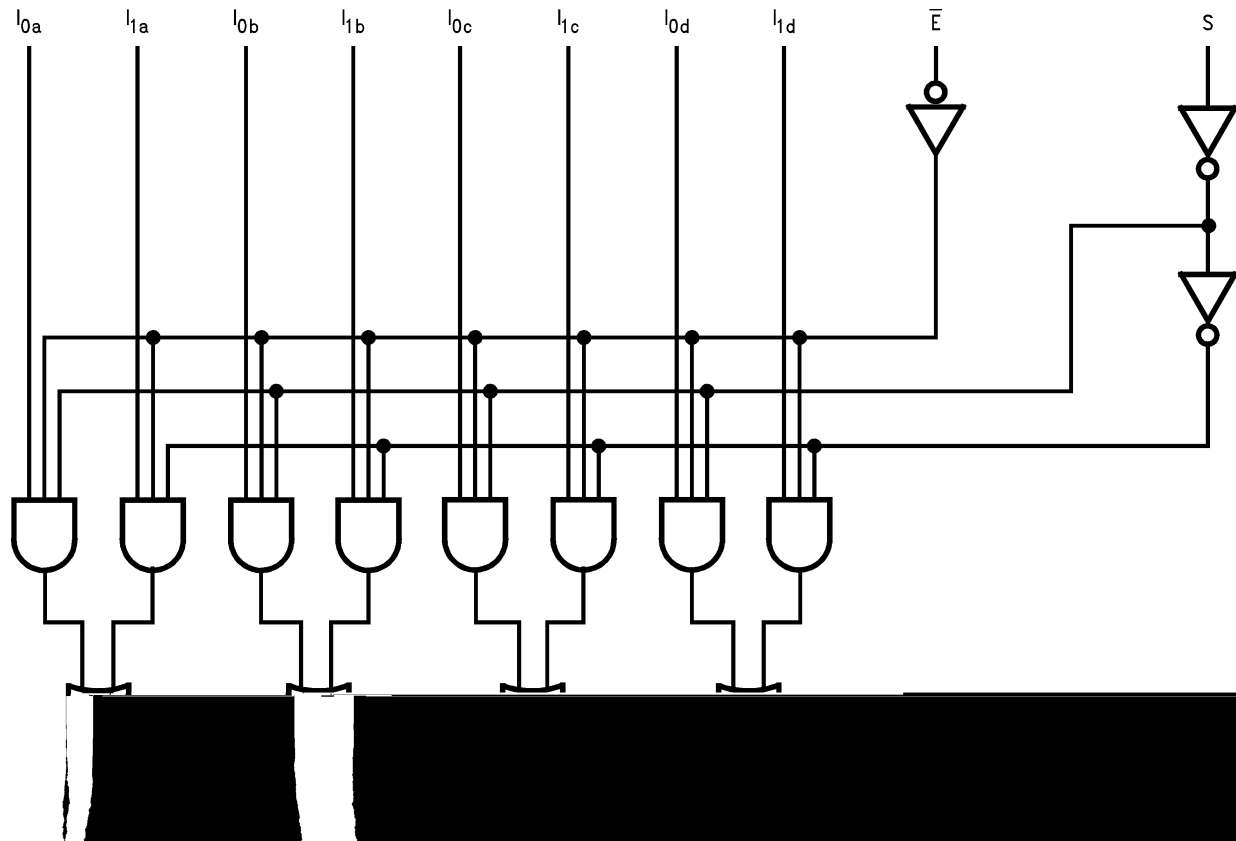

Please note that this diagram is provided only for the understanding of logic operations and should not be used to estimate propagation delays.

V_{CC}	DC Supply Voltage	0.5 to +6.5	V
V_{IN}	DC Input Voltage	0.5 to +6.5	V
V_{OUT}	DC Output Voltage	0.5 to $V_{CC} + 0.5$	V
I_{IN}	DC Input Current, per Pin	± 20	mA
I_{OUT}	DC Output Current, per Pin	± 25	mA
I_{CC}	DC Supply Current, V_{CC} and GND Pins	± 50	mA
I_{IK}	Input Clamp Current	20	mA
I_{OK}	Output Clamp Current	± 20	mA
T_{STG}	Storage Temperature Range	65 to +150	$^{\circ}C$
T_L	Lead Temperature, 1 mm from Case for 10 secs	260	$^{\circ}C$
T_J	Junction Temperature Under Bias	+150	$^{\circ}C$
θ_{JA}	Thermal Resistance (Note 2)	SOIC 16 QFN16 TSSOP 16	126 118 159
P_D			$^{\circ}C/W$

		°		° °		
	2.0 3.0 5.5	1.50 0.7 x V _{CC}			1.50 0.7 x V _{CC}	V
	2.0 3.0 5.5			0.50 0.3 x V _{CC}	0.50 0.3 x V _{CC}	V
A	2.0 3.0 4.5	1.9 2.9 4.4	2.0 3.0 4.5		1.9 2.9 4.4	V
A	3.0 4.5	2.58 3.94			2.48 3.80	
	2.0 3.0 4.5		0.0 0.0 0.0	0.1 0.1 0.1	0.1 0.1 0.1	V
	3.0 4.5			0.36 0.36	0.44 0.44	
	0 5.5			±0.1	±1.0	μA
	5.5			4.0	40.0	μA

		°			
(Note 3)	CL = 50 pF	5.0	0.3	0.8	V

(continued)

				°			° °		
C _{IN}	Input Capacitance	V _{CC} = Open			4	10		10	pF
C _{PD}	Power Dissipation Capacitance	(Note 3)			20				pF

6. C_{PD} is defined as the value of the internal equivalent capacitance which is calculated from the operating current consumption without load. Average operating current can be obtained by the equation: $I_{CC(OPR)} = C_{PD} \cdot V_{CC} \cdot f_{in} + I_{CC}$.

			†
74VHC157MX	VHC157	SOIC 16	2500 / Tape & Reel
74VHC157MTCX	VHC 157	TSSOP 16	2500 / Tape & Reel

†For information on tape and reel specifications, including part orientation and tape sizes, please refer to our Tape and Reel Packaging Specifications Brochure, [BRD8011/D](#).

CASE 485AW
ISSUE O

DATE 11 DEC 2008

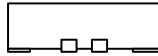
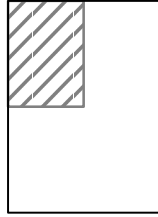

SOIC-16 9.90x3.90x1.50 1.27P
CASE 751B
ISSUE L

SOIC-16 9.90x3.90x1.50 1.27P
CASE 751B
ISSUE L

DATE 29 MAY 2024

**GENERIC
MARKING DIAGRAM***

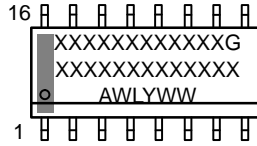

XXXXX = Specific Device Code
A = Assembly Location
WL = Wafer Lot
Y = Year
WW = Work Week
G = Pb-Free Package

*This information is generic. Please refer to device data sheet for actual part marking. Pb-Free indicator, "G" or microdot "•", may or may not be present. Some products may not follow the Generic Marking.

<p>S 1: 1. C C ✓ 2. BAS ✓ 3. ✓ 4. C C ✓ 5. ✓ 6. BAS ✓ 7. C C ✓ 8. C C ✓ 9. BAS ✓ 10. ✓ 11. C C ✓ 12. ✓ 13. BAS ✓ 14. C C ✓ 15. ✓ 16. C C ✓</p>	<p>S 2: 1. CA ✓ 2. A ✓ 3. C C ✓ 4. CA ✓ 5. CA ✓ 6. C C ✓ 7. A ✓ 8. CA ✓ 9. CA ✓ 10. A ✓ 11. C C ✓ 12. CA ✓ 13. CA ✓ 14. C C ✓ 15. A ✓ 16. CA ✓</p>	<p>S 3: 1. C C , #1 ✓ 2. BAS , #1 ✓ 3. , #1 ✓ 4. C C , #1 ✓ 5. C C , #2 ✓ 6. BAS , #2 ✓ 7. , #2 ✓ 8. C C , #2 ✓ 9. C C , #3 ✓ 10. BAS , #3 ✓ 11. , #3 ✓ 12. C C , #3 ✓ 13. C C , #4 ✓ 14. BAS , #4 ✓ 15. , #4 ✓ 16. C C , #4 ✓</p>	<p>S 4: 1. C C , #1 ✓ 2. C C , #1 ✓ 3. C C , #2 ✓ 4. C C , #2 ✓ 5. C C , #3 ✓ 6. C C , #3 ✓ 7. C C , #4 ✓ 8. C C , #4 ✓ 9. BAS , #4 ✓ 10. , #4 ✓ 11. BAS , #3 ✓ 12. BAS , #3 ✓ 13. BAS , #2 ✓ 14. BAS , #2 ✓ 15. BAS , #1 ✓ 16. , #1 ✓</p>
<p>S 5: 1. A , #1 ✓ 2. A , #1 ✓ 3. A , #2 ✓ 4. A , #2 ✓ 5. A , #3 ✓ 6. A , #3 ✓ 7. A , #4 ✓ 8. A , #4 ✓ 9. A , #4 ✓ 10. S C , #4 ✓ 11. A , #3 ✓ 12. S C , #3 ✓ 13. A , #2 ✓ 14. S C , #2 ✓ 15. A , #1 ✓ 16. S C , #1 ✓</p>	<p>S 6: 1. CA ✓ 2. CA ✓ 3. CA ✓ 4. CA ✓ 5. CA ✓ 6. CA ✓ 7. CA ✓ 8. CA ✓ 9. A ✓ 10. A ✓ 11. A ✓ 12. A ✓ 13. A ✓ 14. A ✓ 15. A ✓ 16. A ✓</p>	<p>S 7: 1. S C -C ✓ 2. C A () ✓ 3. C A () ✓ 4. A -C ✓ 5. C A () ✓ 6. C A () ✓ 7. C A () ✓ 8. S C -C ✓ 9. S C -C ✓ 10. C A () ✓ 11. C A () ✓ 12. C A () ✓ 13. A -C ✓ 14. C A () ✓ 15. C A () ✓ 16. S C -C ✓</p>	

DOCUMENT NUMBER: 98ASB42566B	Electronic versions are uncontrolled except when accessed directly from the Document Repository. Printed versions are uncontrolled except when stamped "CONTROLLED COPY" in red.
DESCRIPTION: SOIC-16 9.90X3.90X1.50 1.27P	PAGE 2 OF 2

onsemi and ONSEMI are trademarks of Semiconductor Components Industries, LLC dba onsemi or its subsidiaries in the United States and/or other countries. onsemi reserves the right to make changes without further notice to any products herein. onsemi makes no warranty, representation or guarantee regarding the suitability of its products for any particular purpose, nor does onsemi assume any liability arising out of the application or use of any product or circuit, and specifically disclaims any and all liability, including without limitation special, consequential or incidental damages. onsemi does not convey any license under its patent rights nor the rights of others.

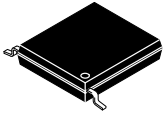

SCALE 2:1

TSSOP-16 WB
CASE 948F
ISSUE B

DATE 19 OCT 2006

onsemi, **onsemi**, and other names, marks, and brands are registered and/or common law trademarks of Semiconductor Components Industries, LLC dba "**onsemi**" or its affiliates and/or subsidiaries in the United States and/or other countries. **onsemi** owns the rights to a number of patents, trademarks, copyrights, trade secrets, and other intellectual property. A listing of **onsemi**'s product/patent coverage may be accessed at www.onsemi.com/site/pdf/Patent-Marking.pdf. **onsemi** reserves the right to make changes at any time to any products or information herein, without notice. The information herein is provided "as-is" and **onsemi** makes no warranty, representation or guarantee regarding the accuracy of the information, product features, availability, functionality, or suitability of its products for any particular purpose, nor does **onsemi** assume any liability arising out of the application or use of any product or circuit, and specifically disclaims any and all liability, including without limitation special, consequential or incidental damages. Buyer is responsible for its products and applications using **onsemi**
