

Low Voltage Dual D-Type Edge-Triggered Flip-Flop

74LVX74

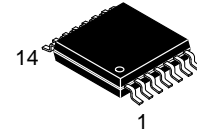

TSSOP-14 WB
CASE 948G

General Description

-
-
-
-

Features

-
-
-
-

Connection Diagram

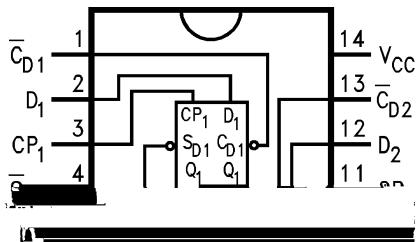

Pin Description

Pin Names	Description
D ₁ , D ₂	Data Inputs
CP ₁ , CP ₂	Clock Pulse Inputs
\overline{C}_{D1} , \overline{C}_{D2}	Direct Clear Inputs
\overline{S}_{D1} , \overline{S}_{D2}	Direct Set Inputs
Q ₁ , \overline{Q}_1 , Q ₂ , \overline{Q}_2	Outputs

MARKING DIAGRAM

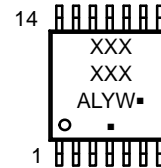

- XXX = Specific Device Code
- A = Assembly Location
- L = Wafer Lot
- Y = Year
- W = Work Week
- = Pb Free Package

(Note: Microdot may be in either location)

ORDERING INFORMATION

See detailed ordering and shipping information on page 5 of this data sheet.

74LVX74

Logic Symbols

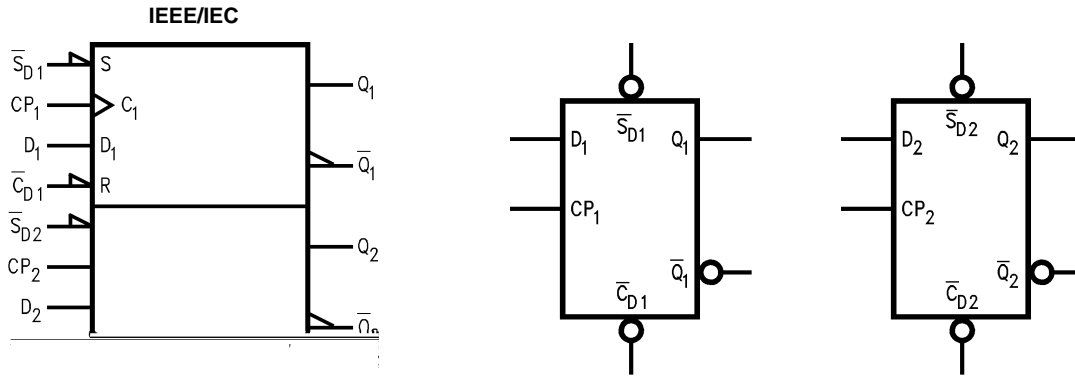

Truth Table (Each Half)

Inputs				Outputs	
\bar{S}_D	\bar{C}_D	CP	D	Q	\bar{Q}
L	H	X	X	H	L
H	L	X	X	L	H
L	L	X	X	H	H

74LVX74

ABSOLUTE MAXIMUM RATINGS

Symbol	Parameter	Rating	Unit	
V_{CC}	Supply Voltage	-0.5 to +6.5	V	
I_{IK}	DC Input Diode Current, $V_I = -0.5$ V	20	mA	
V_I	DC Input Voltage	-0.5 to +6.5	V	
I_{OK}	DC Output Diode Current	$V_O = -0.5$ V	20	mA
		$V_O = V_{CC} + 0.5$ V	+20	mA
V_O	DC Output Voltage	-0.5 to $V_{CC} + 0.5$	V	
I_O	DC Output Source or Sink Current	± 25	mA	
I_{CC} or I_{GND}	DC V_{CC} or Ground Current	± 50	mA	
T_{STG}	Storage Temperature	-65 to +150	$^{\circ}$ C	
P_D	50			

74LVX74



DC ELECTRICAL CHARACTERISTICS

Symbol	Parameter	V _{CC} (V)	Conditions	T _A = 25°C			T _A = -40°C to +85°C		Unit
				Min	Typ	Max	Min	Max	
V _{IH}	HIGH Level Input Voltage	2.0		1.5			1.5		V
		3.0		2.0			2.0		
		3.6		2.4			2.4		
V _{IL}	LOW Level Input Voltage	2.0				0.5		0.5	V
		3.0				0.8		0.8	
		3.6				0.8		0.8	
V _{OH}	HIGH Level Output Voltage	2.0	V _{IN} = V _{IL} or V _{IH} , I _{OH} = -50 μA	1.9	2.0		1.9		V
		3.0	V _{IN} = V _{IL} or V _{IH} , I _{OH} = -50 μA	2.9	3.0		2.9		
			V _{IN} = V _{IL} or V _{IH} , I _{OH} = -4 mA	2.58			2.48		
V _{OL}	LOW Level Output Voltage	2.0	V _{IN} = V _{IL} or V _{IH} , I _{OL} = 50 μA		0.0	0.1		0.1	V
		3.0	V _{IN} = V _{IL} or V _{IH} , I _{OL} = 50 μA V _{IN} = V _{IL}		0.0	0.1		0.1	

74LVX74

AC ELECTRICAL CHARACTERISTICS

Symbol	Parameter	V _{CC} (V)	C _L (pF)	T _A = 25°C			T _A = -40 to 85°C		Unit
				Min	Typ	Max	Min	Max	
t _{PLH} , t _{PHL}	Propagation Delay C \overline{P}_n to Q _n or \overline{Q}_n	2.7	15		7.3	15.0	1.0	18.5	ns
			50		9.8	18.5	1.0	22.0	
		3.3 ± 0.3	15		5.7	9.7	1.0	11.5	
			50		8.2	13.2	1.0	15.0	
t _{PLH} , t _{PHL}	Propagation Delay \overline{C}_{Dn} to \overline{S}_{Dn} to Q _n or \overline{Q}_n	2.7	15		8.4	15.6	1.0	18.5	ns
			50		10.9	19.1	1.0	22.0	
		3.3 ± 0.3	15		6.6	10.1			
			50		9.1	13.6			

	0.10 (0.004)
	SEATING PLANE

onsemi, **onsemi**, and other names, marks, and brands are registered and/or common law trademarks of Semiconductor Components Industries, LLC dba "**onsemi**" or its affiliates and/or subsidiaries in the United States and/or other countries. **onsemi** owns the rights to a number of patents, trademarks, copyrights, trade secrets, and other intellectual property. A listing of **onsemi**'s product/patent coverage may be accessed at www.onsemi.com/site/pdf/Patent-Marking.pdf. **onsemi** reserves the right to make changes at any time to any products or information herein, without notice. The information herein is provided "as-is" and **onsemi** makes no warranty, representation or guarantee regarding the accuracy of the information, product features, availability, functionality, or suitability of its products for any particular purpose, nor does **onsemi** assume any liability arising out of the application or use of any product or circuit, and specifically disclaims any and all liability, including without limitation special, consequential or incidental damages. Buyer is responsible for its products and applications using **onsemi**
