

Designed for general-purpose amplifier and low speed switching applications.

High DC Current Gain –

$$h_{FE} = 3500 \text{ (Typ) @ } I_C = 4.0 \text{ Adc}$$

Collector–Emitter Sustaining Voltage – @ 200 mAdc

$$V_{CEO(sus)} = 60 \text{ Vdc (Min) – 2N6667}$$

$$= 80 \text{ Vdc (Min) – 2N6668}$$

Low Collector–Emitter Saturation Voltage –

$$V_{CE(sat)} = 2.0 \text{ Vdc (Max) @ } I_C = 5.0 \text{ Adc}$$

Monolithic Construction with Built–In Base–Emitter Shunt Resistors

TO–220AB Compact Package

Complementary to 2N6387, 2N6388

These Devices are Pb–Free and are RoHS Compliant*

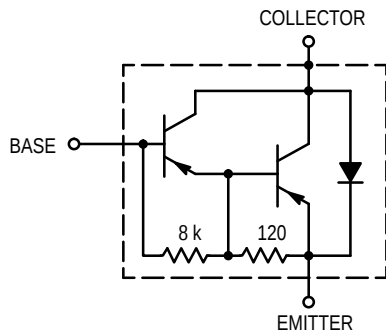
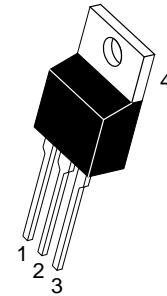

Figure 1. Darlington Schematic

www.onsemi.com

**PNP SILICON
DARLINGTON
POWER TRANSISTORS
10 A, 60–80 V, 65 W**



TO–220
CASE 221A
STYLE 1

MARKING DIAGRAM

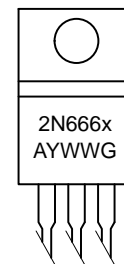

- x = 7 or 8
- A = Assembly Location
- Y = Year
- WW = Work Week
- G = Pb–Free Package

ORDERING INFORMATION

Device	Package	Shipping
2N6667G	TO–220 (Pb–Free)	50 Units/Rail
2N6668G	TO–220 (Pb–Free)	50 Units/Rail

*For additional information on our Pb–Free strategy and soldering details, please download the ON Semiconductor Soldering and Mounting Techniques Reference Manual, SOLDERRM/D.

668

Symbol	2N6667	2N6668	Unit
V_{CEO}	60	80	Vdc
V_{CB}	60	80	Vdc
V_{EB}	5.0		Vdc
I_C	10 15		Adc
I_B	250		mAdc

2N6667, 2N6668

D₁, MUST BE FAST RECOVERY TYPES e.g.,

t_r, t_f ≤ 10 ns
DUTY CYCLE = 1.0%

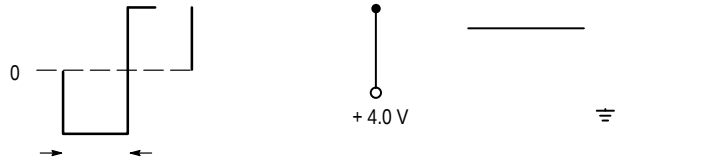

Figure 2. Switching Times Test Circuit

2N6667, 2N6668

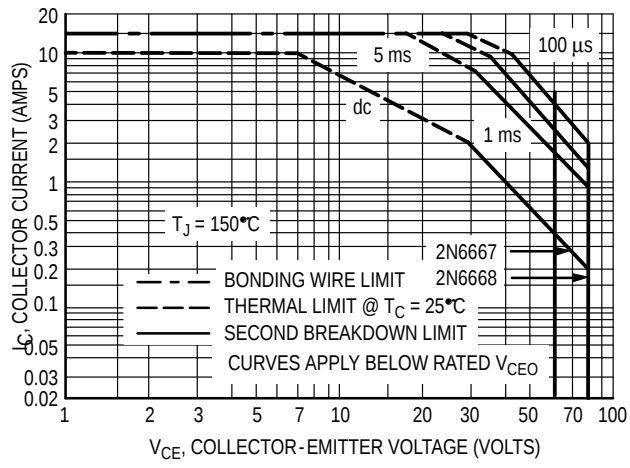

Figure 6. Maximum Safe Operating Area

2N6667, 2N6668

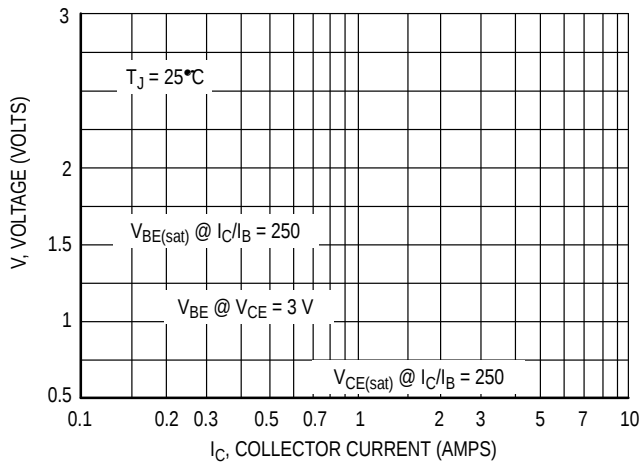

Figure 11. Typical "On" Voltages

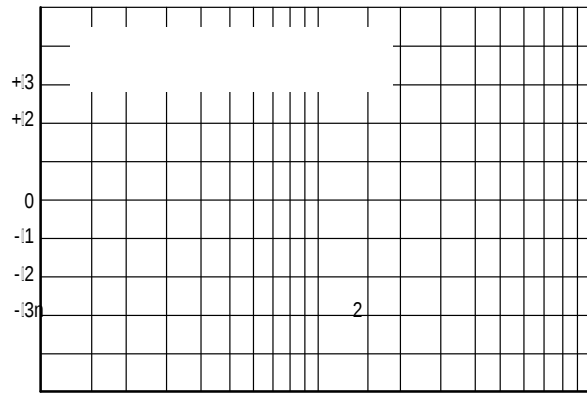

Figure 12. Typical Temperature Coefficients

onsemi, **onsemi**, and other names, marks, and brands are registered and/or common law trademarks of Semiconductor Components Industries, LLC dba "**onsemi**" or its affiliates and/or subsidiaries in the United States and/or other countries. **onsemi** owns the rights to a number of patents, trademarks, copyrights, trade secrets, and other intellectual property. A listing of **onsemi**'s product/patent coverage may be accessed at www.onsemi.com/site/pdf/Patent-Marking.pdf. **onsemi** reserves the right to make changes at any time to any products or information herein, without notice. The information herein is provided "as-is" and **onsemi** makes no warranty, representation or guarantee regarding the accuracy of the information, product features, availability, functionality, or suitability of its products for any particular purpose, nor does **onsemi** assume any liability arising out of the application or use of any product or circuit, and specifically disclaims any and all liability, including without limitation special, consequential or incidental damages. Buyer is responsible for its products and applications using **onsemi**
