



Analysis of Turn On Transient

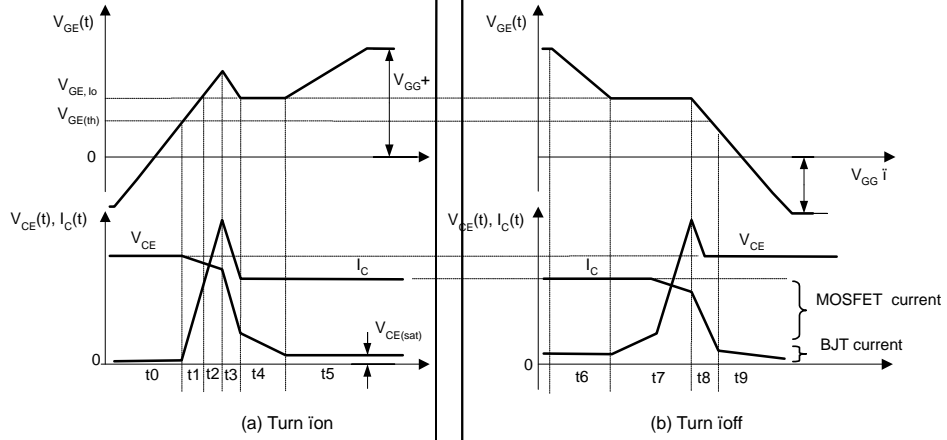

Figure 2. IGBT Switching Waveforms

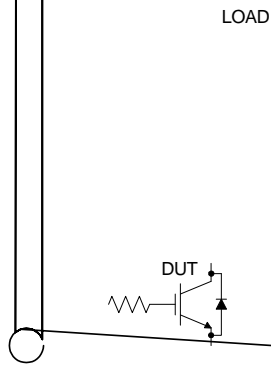

Figure 3. IGBT Switching Test Circuit

across the diode recovers and increases, while  $v_f$  falls, and it falls rapidly as  $C_c$  has small value when  $v_f$  has high value. Due to this phenomenon,  $dv$

### Effect on State

For the same value of  $V_{CE(sat)}$ ,  $I_{CE(sat)}$  is inversely related to the value of  $V_{G+}$ . The smaller the  $V_{G+}$ , the thinner the channel between n+ layer and drift layer becomes, and the resistance in the channel increases. Due to the conductivity modulation effect not found in MOSFET, voltage drop in the ni

(FWD) of the IGBT on the opposite side recovers reverse

When the maximum current is actually measured, one must be aware that it may be less than the calculated amount due to the falling voltage on the wire and stray inductance. When IGBTs are connected in parallel and are operated at a low frequency, low RMS current could lead to a mistaken complacency. However, under such situation, the maximum current would be twice as large, since there are 2 IGBTs in operation, and one must be careful that it could lead to the overload of the power supply of the gate drive. Wattage of the  $R_G$  can be decided with the maximum calculated amount of current.

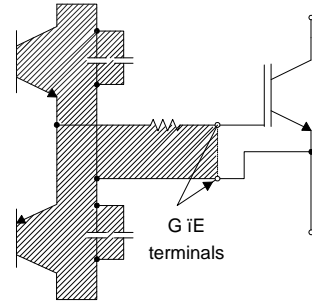

Figure 6. Gate Drive Pattern 6

Gate Drive Layout Considerations

Effect of Gate Line Inductance on the Induced Turn-on

Possibility of induced turn-on is greater, as the gate drive impedance is increased during turn-on and turn-off transient due to stray inductance from the line connected with the gate. As gate impedance becomes smaller, more current flows through  $R_G$  to reduce the charging current of  $C_{ge}$ , which causes the amount of increase in  $V_{GE}$  to reduce. In order to prevent this, leakage inductance from DC power supply must be minimized, and  $R_G$  should be kept at minimum.

The final push-pull wiring pattern should be short and thick, and if a direct connection between the gate drive and the IGBT is not possible, then gate wire and the emitter wire could be twisted to reduce stray inductance. In addition, if the area of the loop that encompasses the final push-pull stage, the power source pattern, and G+ terminals of the IGBT is minimized as shown in Figure 6, effect on the  $V_{GE}$  from  $di/dt$  could be minimized when  $V_{GE+}$  is injected.

Power Source Stabilizing Capacitor

During IGBT switching, current flows to the gate, and at that time, supply voltage of the gate circuit can oscillate. As a result, the gate drive loss can exceed the designed amount, or it could reduce the short circuit capability. In such case, it is advised to keep PCB pattern wide and flat and use enough capacitor for supply voltage stability.

Common Emitter Problems

Isolation Problem

In half bridge topology and similar systems, the upper IGBT gate drive circuits must be insulated from the bottom IGBT circuits. The control board and the gate drive must also be insulated because the upper IGBT emitter free floats as the IGBT switches. As the power DC voltage rises, the insulating voltage should also rise accordingly. In general, the insulating voltage should be at least twice the rated voltage for the IGBT. In addition, care has to be taken with the noise that comes about from insulating interface. Immunity to noise differs depending on the how and where the circuits lines are placed, so wiring and placement should be designed to minimize parasitic capacitance. Parasitic capacitance should be minimized to reduce  $dv/dt$  coupling noise between neighboring drive circuits. When using a common transformer to provide current to both the upper and the lower gate drive, the wire must be wound to minimize combined capacitance. In using optocoupler, the optocoupler must have insulating capacity with high commonmode voltage and transient noise immunity. Upper and lower, or different types of gate leads of the gate drive must not be wound together.

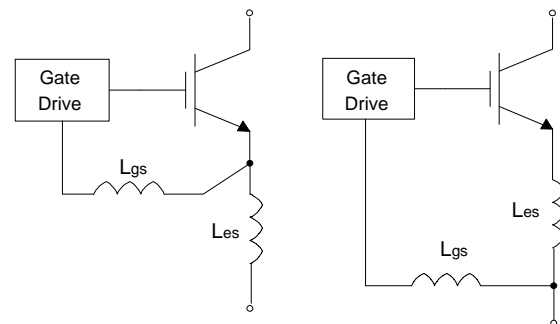

Figure 7. Common Emitter

At the time of switching, voltage is induced across the stray inductance of the power circuit because of  $di/dt$  from the main current. When control signals from the gate drive and the same path as the main current are used, gate voltage decreases during turn-on, and voltage is added to the gate voltage during turn-off to slow the turn-on/turn-off. As such, it is better not to share stray inductance between control emitter terminal and power emitter terminal. As such, control emitter terminal and power emitter terminal should be separate. If the two terminals are together, common emitter inductance increases to slow the switching speed and switching loss.

Voltage oscillation, slow gate voltage rise, noise immunity deterioration, gate voltage reduction, falling gate protection circuit efficiency are some of the effects of the layout. These can be solved with designs to reduce stray

inductance and stray resistance such as making patterns short and thick. In addition, attention must be paid to the power circuit layout to minimize stray inductance. For example, the area of the closed loop must be minimized with DC link capacitor, load, power output, half-bridge leg and snubbers in the case of inverter, and in the case of resistive load, line to the load should be twisted to reduce the stray inductance of the power circuit, while snubber should be strengthened depending on the amount of overvoltage for inductive load. As the frequency increases, voltage could change due to slowing response of the dc link capacitor, so high speed electrolytic cap for inverter should be used, and capacitor with better characteristics such as film capacitor should be inserted in the main cap in parallel.

Conclusion

We have examined some issues to consider in the gate

IGBT's latch-up. It is possible to obtain short circuit time with short circuit testing of different products from many companies. In general, short circuit time becomes longer with high saturation voltage and  $V_{CE(sat)}$ . (In measuring  $V_{CE(sat)}$  gate voltage should be enough for the minimum value of  $V_{CE(sat)}$  and that level must be maintained during fault test.)

Types of Short Circuit

Short circuit can happen while IGBT's normal function. Short circuit can be divided into two different types. The first is short-circuiting when the device was in on state, which is called "fault under load" and the second is a circumstance where the device turns on under short circuit, which is called "hard switch fault".

Type I. Fault Under Load (FUL)

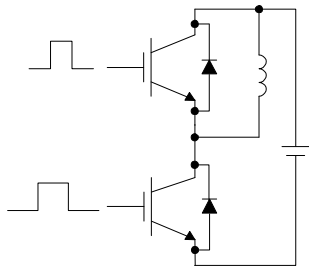

Figure 9. Fault Under Load Test Circuit

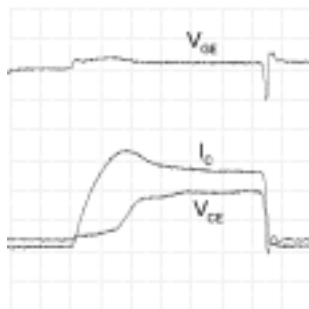

Figure 10. Fault Under Load Waveform

Fault under load (FUL) is a situation where short circuit takes place when the device is in on state, so  $V_{ce}$  is low



### Short Circuit Protection

We have discussed types of short circuits, and several ways to prevent short circuits have been reviewed. However, methods mentioned above are not fundamental ways to deal with short circuit, so there has to be a way to safely turn off the device when it short circuits.

### Protecting Against Overcurrent Condition

Overcurrent is when more than the rated current flows through the system, and it can be classified into overload, short circuit, and turn-off overcurrent. In traditional applications, overcurrent is possible in several cases. Generally, overcurrent from overload comes from inrush current, filter inrush and a rapid change in load during beginning of operation of electrical devices. In this case, we can only rely on short circuit capability of the device. Overload, in general, lasts much longer than the IGBT's short circuit endurance time. As such, other methods must be sought to remove the overload. Closed loop control moderates the timing signal of the gate drive pulse, to modify the time of switching, and this is used to keep the current output at a determined level. Response control of the control loop would have to be set to the rate of changes in the current and pace of the electrical devices or filter inductance. Protection from overcurrent due to short circuit is different from turn-off over current. In the following sections, protection from short circuit would be discussed.

### Protecting Against Short Circuit Current Condition

In the overload situations mentioned above, removing the closed loop does not considerably shorten the life of the IGBT. On the other hand, short circuit provides worse condition for the life of the device than overload or the overcurrent at turn-off, and there are ground faults, terminal-to-terminal faults. Such short circuit current bypasses the electrical devices or filter inductance and increases rapidly for IGBT to flow. Conventional PWM loop controls power output, but it has no control over this type of fault. At the beginning of the fault, the IGBT must withstand with its own short circuit capability, and protection mechanism receives the fault signal to reduce the gate voltage while IGBT withstands the short circuit. However, if the fault disappears while during IGBT's endurance time, then the IGBT must continue to function and must not turn off unnecessary devices or turn off the entire system. The most notable is the IGBT turn-off overcurrent due to the reverse recovery current of the diode. As such, the protection circuit must be designed to return the circuit to normal operation if the fault is removed before the IGBT shuts down the system.

When conduction time increases, the border of SOA (SCSOA) decreases. Junction temperature increases



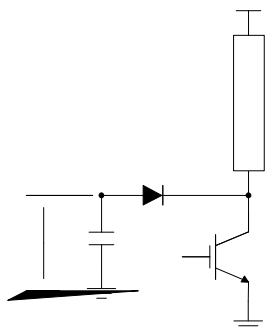

Figure 15. Short Circuit Sensing Circuit using De-saturation Method

## Snubber Circuit

### Types of Snubber Circuits and their Features

Snubber circuit is a supplementary circuit used in the converter circuit to reduce stress put on the power semiconductor. The ultimate goal of the snubber circuit is to improve the transient waveform. The snubber circuit suppresses overcurrent or overvoltage or improves  $dv/dt$  and  $di/dt$  to ease the transient waveform to reduce stress on the device. There are many uses for snubber circuits, but this discussion will center on its ability to suppress overcurrent at turn-off.

Snubber circuit can be divided into those connected in between the DC power supply bus and ground, and those connected to each IGBT. The first types of circuits include RC snubber circuits, charge and discharge RCD snubber circuits and discharge-suppressing RCD snubber circuits, and the second type includes C snubber circuits and RCD snubber circuits. The following are detailed descriptions of each snubber circuit.

### RC Snubber Circuit

This snubber circuit is effective in turn-off surge voltage and is suitable for chopper circuits. It is also effective for oscillation by parasitic reactance and  $dv/dt$  noise. However, when it is applied in large capacity IGBT, resistance for the snubber must be set low due to dissipation heat, so it has the disadvantage of worsening loading conditions at turn-on. Loss at snubber itself is quite large, so it is not suitable for high frequency. In very large capacity IGBT circuit, it is better to use small snubber "RC snubber circuit" along with the main snubber "discharge-suppressing RCD snubber circuit." When used together, it helps parasitic oscillation control of the main snubber loop. Main applications include arc welder and switching power supply.

### Charge and Discharge RCD Snubber Circuit

This snubber suppresses overvoltage at turn-off to reduce switching losses at turn-off, and its effectiveness in surge voltage suppression is about average. The snubber capacitor is completely discharged at turn-on, and it is fully recharged at turn-off. Unlike the discharge-suppressing RCD snubber circuit below which acts as a clamp, this circuit of 4e

increases to present problems in controlling overvoltage.  
In such large current applications, discharge suppressing

References

- [1] Malay Trivedi and Krishna Shenai, "Failure Mechanism of IGBT's Under Short-Circuit and Clamped Inductive Switching Stress," IEEE Trans. Power Electronics, vol. 14, no. 1, pp. 108-116, 1999.
- [2] Rahul S. Chokhawala and Saed Sobhani, "Switching Voltage Transient Protection Schemes for High Current IGBT Modules," IEEE Trans. Industry Applications